

A-D-E quivers and baryonic operators

Yuji Tachikawa

*School of Natural Sciences, Institute for Advanced Study,
Princeton, New Jersey 08540, U.S.A.
E-mail: yujitach@ias.edu*

Futoshi Yagi

*Department of Physics, University of Tokyo
7-3-1 Hongo, Bunkyo-ku, Tokyo, 113-0033 Japan
E-mail: yagi@hep-th.phys.s.u-tokyo.ac.jp*

ABSTRACT: We study baryonic operators of the gauge theory on multiple D3-branes at the tip of the conifold orbifolded by a discrete subgroup Γ of $SU(2)$. The string theory analysis predicts that the number and the order of the fixed points of Γ acting on S^2 are directly reflected in the spectrum of baryonic operators on the corresponding quiver gauge theory constructed from two Dynkin diagrams of the corresponding type. We confirm the prediction by utilizing techniques to enumerate baryonic operators of the quiver gauge theory which includes the gauge groups with different ranks. We also find that the Seiberg dualities act on the baryonic operators in a non-Abelian fashion.

KEYWORDS: AdS-CFT Correspondence, D-branes, Supersymmetry and Duality.

Contents

1. Introduction	2
2. Review of the correspondence for $T^{1,1}$	6
3. Quivers for $T^{1,1}/\Gamma$	8
3.1 A-D-E classification of $SU(2)$ subgroups	8
3.2 Geometry	11
3.3 Construction of the quiver	11
3.4 Some checks of the correspondence	13
4. Baryons on $T^{1,1}/\Gamma$	14
4.1 \mathcal{B} -type baryons	15
4.2 \mathcal{A} -type baryons	16
4.2.1 Geometry	16
4.2.2 Gauge theory	16
5. \mathcal{A}-type baryons on $T^{1,1}/\Gamma$: direct analysis	18
5.1 Some examples	18
5.2 Untangling procedure	20
5.3 Action of the Seiberg duality	22
5.4 Classification of \mathcal{A} -type baryons	23
5.4.1 Cyclic groups \mathbb{Z}_{2n}	24
5.4.2 Dihedral groups \widehat{D}_n	24
6. Baryonic operators and quiver representations	26
6.1 Generalized determinants	27
6.2 Relation to quiver representations	29
6.3 Theorems of Gabriel and Kac	30
6.4 Application to the study of \mathcal{A} -type baryons	32
7. Dimension of the \mathcal{A}-type baryonic branch	35
7.1 Dimension of the moduli space	36
7.2 Number of generators	36
8. Summary and discussion	38
A. Tables of representations of discrete subgroups of $SU(2)$	39
B. Fractional dibaryons as generalized determinants	40
C. Direct analysis of \mathcal{A}-type baryons, continued.	41

1. Introduction

AdS/CFT and baryons. $\mathcal{N} = 4$ super Yang-Mills theory with gauge group $SU(N)$ is now believed to be equivalent to Type IIB string theory on $AdS_5 \times S^5$ with N units of the five-form flux [1], which is the prototypical example of the Anti-de Sitter/Conformal Field Theory (AdS/CFT) correspondence. This amazing correspondence relates a theory with gravity and a genuine gauge theory. Moreover, it requires the full non-perturbative spectrum of the superstring theory in the gravity side. For example, the baryons, i.e. operators which involves the epsilon symbols of the gauge group, correspond to various wrapped D-branes [2, 3].

The duality can be generalized by replacing S^5 by other five-dimensional Einstein manifolds X^5 . The corresponding gauge theory is the low energy limit of the theory on N D3-branes probing the six-dimensional cone $C(X^5)$ over X^5 , and there should be a mapping between D-branes wrapped on X^5 and baryonic operators of the gauge theory.

One well-studied example [4] is to take $X^5 = T^{1,1}$ which is an S^1 bundle over $S^2_1 \times S^2_2$. The dual is an $\mathcal{N} = 1$ supersymmetric gauge theory with the group $SU(N)_1 \times SU(N)_2$ and four bifundamental chiral superfields A^i, B^j ($i, j = 1, 2$), which we call the conifold gauge theory. We use the quiver diagram to summarize the matter content, see figure 1. There, each of the nodes signifies an $SU(N)$ gauge group, and an arrow between the two nodes stands for a bifundamental chiral superfield, i.e. a chiral superfield transforming in the fundamental(\square)/anti-fundamental($\bar{\square}$) representation under the gauge groups at the head/tail of the arrow, respectively. We say such a bifundamental field connects the gauge group at the tail and the one at the head. Then A^i and B^j transform as the representations $(\bar{\square}, \square)$ and $(\square, \bar{\square})$ under $SU(N)_1 \times SU(N)_2$, respectively. We often abuse the terminology and just used the word the quiver to mean either the gauge theory or the diagram. There are two $SU(2)$ symmetries acting on the indices i of A^i and j of B^j respectively, and they correspond to the rotation of S^2_1 and S^2_2 in the geometry.

D3-branes wrapped on the S^3 part of $T^{1,1} \sim S^2 \times S^3$ have been successfully identified [5] with determinants of the bifundamentals A^i and B^j , see figure 2. These operators are called dibaryons, since we used two epsilon symbols to construct them.

Our focus in this paper is the orbifold of $T^{1,1}$ by a discrete subgroup $\Gamma \subset SU(2)_1$ of the isometry. $T^{1,1}/\Gamma$ has various types of three-cycles, of the form S^3/\mathbb{Z}_n or S^3/Γ . Since the volume of the three-cycle is proportional to the dimension of the dual operator, it translates to a rich and intricate spectrum of baryonic operators of the dual gauge theory. Our objective in this article is then to establish the one-to-one mapping between them.

People have studied the mapping of baryons and wrapped D-branes in various dual pairs, e.g. for S^5/\mathbb{Z}_3 in [6], for generalized conifolds and del Pezzos in [7–10]. Quite recently people started to enumerate baryonic operators systematically for X^5 with $U(1)^3$

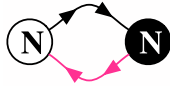

Figure 1: Conifold gauge theory

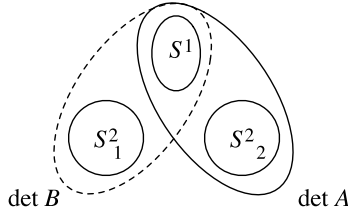

Figure 2: Dibaryons on $T^{1,1}$.

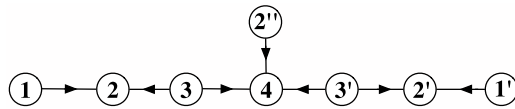

Figure 3: Subquiver of the octahedral theory.

isometry [11–13]. Our setup is arguably simpler than these previous works in the gravity side. Indeed, the action of Γ on the S^2 of $T^{1,1}$ is exactly as the symmetry group of a regular polyhedron, which has been known to us since the days of classical Greek natural philosophers. It allows us to concentrate on and uncover the dual phenomena on the gauge theory side, which will be the main topic of this article.

McKay correspondence and baryons. As is well known, discrete subgroups Γ of $SU(2)$ are exhausted by cyclic groups \mathbb{Z}_n , binary dihedral groups \widehat{D}_n and binary tetra-, octa- and icosahedral groups \widehat{T} , \widehat{O} , \widehat{I} . It follows the pattern A_n , D_n and $E_{6,7,8}$, which can be understood following the observation of McKay [14]. There, one associates a node of the extended Dynkin diagram to each irreducible representation of the corresponding group, and the edges encode the decomposition of the tensor product of the irreducible representation with the standard two-dimensional representation. The McKay correspondence has a physical realization using D3-branes probing \mathbb{C}^2/Γ [15], where the nodes of the Dynkin diagram correspond to the fractional branes at the origin, and the edges to the open strings stretching between two fractional branes.

Application of the procedure to our case produces a quiver gauge theory which includes the alternating extended Dynkin diagram as a subquiver, which we will see in more detail in section 3. We call them alternating in the sense that the arrows are all incoming or all outgoing at each node. For example, we get the subquiver in figure 3 if we take the binary octahedral group \widehat{O} as the orbifold group Γ . A number k in the circle stands for an $SU(Nk)$ gauge group, and primes are used to distinguish different gauge groups with the same ranks.

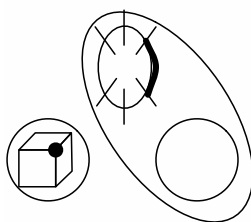

Figure 4: D3-brane on $T^{1,1}/\Gamma$.

What will be the spectrum of the baryonic operators of this quiver? From the AdS/CFT correspondence, it should reproduce the structure of three-cycles of $T^{1,1}/\Gamma$, and we will see shortly that it is dictated by the action of Γ on S^2 . In other words, we can expect that the baryonic spectrum of the Dynkin quiver ‘knows’ the action of Γ .

Let us take $\Gamma = \hat{\mathcal{O}}$ again as the example, and consider D3-branes wrapped at S^3_2 which is an S^1 bundle over S^2_2 , see figure 4. We have the choice on which point of S^2_1 to put the D3 brane. When we put the D3-brane at a vertex of the cube, $\mathbb{Z}_6 \subset \hat{\mathcal{O}}$ acts on the D3-brane worldvolume as the $1/6$ -rotation of the S^1 fiber. Therefore, it is $1/6$ times as heavy as the dibaryon of the unorbifolded theory. The worldvolume is S^3/\mathbb{Z}_6 , and thus we have a choice of the Wilson line $\alpha^6 = 1$, which leads to six operators of the same dimension of the gauge theory [16]. Similarly, by putting the D3-brane at the center of a face or at the midpoint of an edge, we have a wrapped D3-brane which is $1/8$ and $1/4$ as heavy as the original dibaryon. The D3-brane at generic points of S^2_1 is half as heavy as the baryon of the unorbifolded theory, but it has the moduli space and we need to quantize it.

We will carry out the analysis of the geometry in detail in section 4, and the general statement about the spectrum of the baryons for non-Abelian Γ is the following: Let Γ be a discrete subgroup of $SU(2)$, generated by elements a, b, c and z by the relation $a^p = b^q = c^r = z$, and $z^2 = 1$. Consider an alternating extended Dynkin quiver of the same type Γ . Then, the baryonic operators of the quiver are generated by the following sets of operators

$$\begin{aligned}
 \mathcal{P}_1 \dots, \mathcal{P}_p & : \text{of weight } |\Gamma|/(2p), \\
 \mathcal{Q}_1 \dots, \mathcal{Q}_q & : \text{of weight } |\Gamma|/(2q), \\
 \mathcal{R}_1 \dots, \mathcal{R}_r & : \text{of weight } |\Gamma|/(2r), \\
 \mathcal{O}(N)\text{operators} & : \text{of weight } |\Gamma|/2.
 \end{aligned} \tag{1.1}$$

Here the weight of the operator is defined as the number of bifundamental fields in it, divided by N .

A large part of our paper is devoted to check this prediction in the gauge theory. In fact, this mathematical statement about the alternating Dynkin quiver was proved in [17], and the AdS/CFT correspondence with $T^{1,1}/\Gamma$ gives a string-theoretic reason of existence of such a theorem. The proof in [17] was done without reference to the discrete group Γ , whereas we analyze the problem emphasizing its relation to the McKay correspondence.

Non-toric/non-conformal quiver and baryons. One distinguishing feature of the space $T^{1,1}/\Gamma$ for non-Abelian Γ is that the isometry is reduced to $SU(2) \times U(1)$ of rank 2. It is a non-toric Einstein manifold and correspondingly we have SU gauge groups of different ranks in the quiver gauge theory. Baryonic operators on such a theory is much subtler compared to the baryons of toric quiver gauge theory.

The problem is that the bifundamentals are no longer square matrices, therefore we can no longer form simple determinants from them. Let us again consider the alternating quiver for $\Gamma = \widehat{O}$, figure 4. One gauge-invariant operator is of the form

$$\varepsilon_{(1)}(A_{1 \rightarrow 2})^N \varepsilon_{(2)}(A_{3 \rightarrow 2})^N \varepsilon_{(3)}(A_{3 \rightarrow 4})^{2N} \varepsilon_{(4)}(A_{2'' \rightarrow 4})^{2N} \varepsilon_{(2'')} \quad (1.2)$$

where $A_{a \rightarrow b}$ is the bifundamental between $SU(aN)$ and $SU(bN)$ gauge groups, and $\varepsilon_{(k)}$ is the epsilon symbol for $SU(kN)$. It is a product of $6N$ fields, i.e. of weight six.

Now $|\widehat{O}| = 48$ and $(p, q, r) = (4, 3, 2)$, and we saw above that the AdS/CFT correspondence predicted the lowest weight of the baryonic operator is $|\widehat{O}|/(2p) = 6$. We need to construct three others, and show that they exhaust gauge-invariant fields made of $6N$ bifundamentals.

One might be able to construct other baryonic operators by inspection, but it requires systematic techniques to enumerate and classify them. We develop two such techniques in this article. One is the untangling procedure which is based on the relation

$$\varepsilon^{i_1 \dots i_k a_1 \dots a_{N-k}} \bar{\varepsilon}_{j_1 \dots j_k a_1 \dots a_{N-k}} \propto \delta_{j_1}^{[i_1} \dots \delta_{j_k}^{i_k]}. \quad (1.3)$$

Another is the application of the theory of quiver representations, where we will find a baryonic operator can be naturally associated to an indecomposable representation of the quiver. In the previous application of the quiver representations in string theory, the dimensions of the vector spaces associated to the nodes are identified with the ranks of the gauge groups. A curious feature of our case is that the dimensions correspond to the number of the epsilon symbols used in the baryonic operator. We will also see that the action of Seiberg dualities on the baryons is quite non-trivial, and that it can be utilized in the classification.

The appearance of gauge groups of different ranks is also a prominent feature of non-conformal deformations of toric quiver gauge theory, and the techniques we develop will hopefully have some utility in studying baryons and baryonic branches of these non-conformal theories.

Organization of the paper. The rest of the article is structured as follows: we start the discussion in section 2 by reviewing the known correspondence of the conifold gauge theory and Type IIB string on $AdS_5 \times T^{1,1}$. In section 3, we review the McKay correspondence and the construction of Douglas and Moore, and apply them to obtain the quiver gauge theory dual to Type IIB string on $AdS_5 \times T^{1,1}/\Gamma$. We also perform some elementary check of the AdS/CFT correspondence in our cases. Then in section 4, we study the spectrum of D3 branes wrapping three-cycles of $T^{1,1}/\Gamma$, and we construct the corresponding baryonic operators in the quiver gauge theory. In sections 5 and 6 we proceed to show that the operators constructed up to that point exhaust the baryonic operators of the quiver gauge

theory, which requires a quite lengthy analysis. We use in section 5 a direct approach which analyze the structure of the contraction of the indices of the epsilon tensors, whereas in section 6 we employ the mathematical theory of the quiver representations to classify the baryonic operators. Each approach has its own virtues and we think they provide a valuable tool to analyze baryonic operators of non-toric and/or non-conformal quiver gauge theories. Finally in section 7 we show that the generators of the baryonic operators have no non-linear constraint among them if $N > 1$. Therefore the baryonic chiral ring of the alternating Dynkin quiver is just a polynomial ring with generators determined by the geometry of S^2/Γ , agreeing with the mathematical result in [17]. We conclude our article by a discussion about future prospects in section 8. We have several appendices which complement the main discussion.

Note added in the published version. The authors were informed after submitting the version 1 of the paper on the arXiv that the result about the baryons of the alternating Dynkin quiver was proved in a mathematical paper [17] in 2000 in a different method. The authors would like to thank Yoshiyuki Kimura for finding out the reference [17]. The wording of the published version of the paper was modified accordingly. The readers can think of the work either as a further check of the AdS/CFT correspondence using the known mathematical result, or as a ‘postdiction’ of it from the application of the correspondence to $T^{1,1}/\Gamma$.

2. Review of the correspondence for $T^{1,1}$

Let us begin by recalling the AdS/CFT correspondence for the case of Type IIB string theory on $T^{1,1} \times AdS_5$. The metric for the five-dimensional space $T^{1,1}$ is given by

$$ds_{T^{1,1}}^2 = \frac{1}{6} \sum_{i=1,2} (d\theta_i^2 + \sin^2 \theta_i d\phi_i^2) + \frac{1}{9} (d\psi + \cos \theta_1 d\phi_1 + \cos \theta_2 d\phi_2)^2 \quad (2.1)$$

where $0 \leq \theta_i < \pi$ and $0 \leq \phi_i < 2\pi$ parametrize $S^2_1 \times S^2_2$ in an obvious way, and $0 \leq \psi < 4\pi$ is the coordinate of the S^1 fiber over it. The set (θ_i, ϕ_i, ψ) for each i describes the three-manifold which is topologically S^3 in the form of the Hopf fibration, although the fiber direction is squashed compared to the round sphere. Still it has $SU(2)_i$ isometries for $i = 1, 2$ acting on each set of coordinates (θ_i, ϕ_i, ψ) . Combined with the shift of ψ , $T^{1,1}$ has the isometry group $SU(2)_1 \times SU(2)_2 \times U(1)$.

The metric cone C over $T^{1,1}$ is the well-known conifold, which has an alternative description as a hypersurface determined by $xw = yz$ in $(x, y, z, w) \in \mathbb{C}^4$. Now, let us consider Type IIB string theory on $\mathbb{R}^{3,1} \times C$, and introduce $N \gg 1$ of D3 branes which fill $\mathbb{R}^{3,1}$ direction. Since the conifold C is Calabi-Yau, there remains $\mathcal{N} = 1$ supersymmetry in four dimensions. The gauge theory on the stack of D3 branes should have N -th symmetric product of the conifold as a branch of the moduli space, and is known to be described by the gauge theory whose matter content is summarized in figure 1.

To specify an $\mathcal{N} = 1$ supersymmetric gauge theory we need to give the superpotential, which is

$$W = \varepsilon_{ij} \varepsilon_{kl} \text{tr} A^i B^k A^j B^l \quad (2.2)$$

for the conifold theory. Then, F-term and D-term conditions can be satisfied by taking all of A^i and B^k diagonal matrices, and thus a branch of the moduli space is given by the N -th symmetric product of the space described by the first entries of A^i and B^j . Let us call them a^i and b^j . The gauge-invariant combinations of them are

$$x = a^1 b^1, \quad y = a^1 b^2, \quad z = a^2 b^1, \quad w = a^2 b^2, \quad (2.3)$$

which satisfy $xw = yz$ by construction. Thus we confirmed the gauge theory has the N -th symmetric product of the conifold as a branch in the moduli space.

Let us now put all of the D3 branes at the tip of the conifold. For large $N \gg 1$, the tension of the branes bends the spacetime, and the low-energy dynamics is captured by the near-horizon geometry which is $T^{1,1} \times AdS_5$ with N units of the 5-form flux through $T^{1,1}$. AdS_5 has the isometry $SU(2, 2)$, which is isomorphic to the conformal group of $\mathbb{R}^{3,1}$. The proposal by Maldacena [1], applied in this context, means that the dynamics of the near-horizon region is dual to that of the low-energy limit of the conifold gauge theory, which should be a non-trivial conformal field theory.

There are various tests of this AdS/CFT correspondence. Firstly, the low-energy limit of the gauge theory should be superconformal. Let us suppose it is so; then the scaling dimension of the superpotential should be three. It is most natural to assign the scaling dimension $3/4$ to A^i and B^j by the consideration of the symmetry. Now the Novikov-Shifman-Vainshtein-Zakhalov (NSVZ) beta functions for the gauge coupling constants of two $SU(N)$ groups vanish with this scaling dimension for the bifundamental fields, which is as it should be for a superconformal field theory. Internal global symmetries also agree. Indeed, two $SU(2)$ symmetries acting on A^i and B^j and the $U(1)$ R-symmetry of the gauge theory nicely account for the isometry $SU(2)_1 \times SU(2)_2 \times U(1)$ of $T^{1,1}$. There is one additional global symmetry which we call the baryonic charge, which assigns charge $+1$ to A^i and -1 to B^j . It comes from the 4-form potential reduced along S^3 in $T^{1,1}$.

Second is the matching of the central charges a and c calculated in the gravity and the gauge theory descriptions [18]. In the gauge theory side, they can be determined from the 't Hooft anomaly of the R-symmetry, using the formula

$$a = \frac{3}{32} (3 \text{tr} R^3 - \text{tr} R), \quad c = \frac{1}{32} (9 \text{tr} R^3 - 5 \text{tr} R), \quad (2.4)$$

where the trace runs over the Weyl fermions of the ultraviolet theory. The R-charges of a chiral superfield is fixed to be two thirds of its scaling dimension, so in this case we have

$$a = c = \frac{27}{64} N^2 \quad (2.5)$$

in the large N limit. In the gravity side, the central charges are determined [19] by the response of the bulk metric to the boundary perturbation via the prescription of [20, 21], with the result

$$a = c = \frac{N^2 \pi^3}{4 \text{Vol} X} \quad (2.6)$$

where $\text{Vol} X$ is the volume of the internal Einstein manifold normalized to have $R_{mn} = 4g_{mn}$. From the explicit metric (2.1) of $T^{1,1}$, we find

$$\text{Vol} T^{1,1} = \frac{16}{27} \pi^3, \quad (2.7)$$

which reproduces (2.5) after substituting in (2.6).

Third is the correspondence of the dibaryon operators [5] in the gauge theory and the wrapped D3-branes in $T^{1,1}$. Dibaryon operators are the following gauge-invariant operators

$$\det A^{i_1, \dots, i_N} \equiv \varepsilon_1 \varepsilon_2 A^{i_1} \dots A^{i_N}, \quad \det B^{j_1, \dots, j_N} \equiv \varepsilon_1 \varepsilon_2 B^{j_1} \dots B^{j_N}, \quad (2.8)$$

which are called as such because two epsilon symbols are necessary to construct them. Here $\varepsilon_{1,2}$ are the epsilon symbols for $SU(N)_{1,2}$ respectively, and we omitted the gauge indices for simplicity. The $SU(2)_1$ indices i_1, \dots, i_N and the $SU(2)_2$ indices j_1, \dots, j_N are automatically symmetrized because of the presence of the two epsilon symbols, and thus they come in the spin $N/2$ representation of the $SU(2)_{1,2}$ global symmetry groups. They have scaling dimensions $3N/4$, and should correspond to heavy objects in the bulk geometry.

In fact, they are known to be represented by D3-branes wrapping S^3 of $T^{1,1}$ [22]. One family of S^3 , which we call the \mathcal{A} -family, is given by fixing (θ_1, ϕ_1) , and the worldvolume is parametrized by (θ_2, ϕ_2, ψ) . Another family, which we call the \mathcal{B} -family, is given by exchanging (θ_1, ϕ_1) and (θ_2, ϕ_2) in the description above. These S^3 are known to be supersymmetric cycles, which corresponds to the fact that the dibaryons preserves half of the supersymmetries. Their mass, calculated from the tension of the D3 brane, matches with the dimension of the dibaryon operators [22]. As they wrap non-trivial homological cycles, they carry associated conserved charges. The fact that S^3 of the \mathcal{A} - and \mathcal{B} - family are homologically opposite to each other fits nicely to the fact that the baryonic charges of the dibaryons $\det A$ and $\det B$ are opposite to each other. Finally one can calculate the $SU(2)_{1,2}$ spin of each of the family. For the \mathcal{A} -family, the low-energy dynamics of the brane are given by the supersymmetric quantum mechanics of the motion of its center-of-mass coordinates on S^2 parametrized by (θ_1, ϕ_1) . As detailed in [22], the Chern-Simons coupling of the D3 brane to the N units of the 5-form flux in the geometry leads to the presence of N units of the magnetic flux through S^2 . It leads to $N + 1$ zero-modes of the Hamiltonian of the motion of the brane, which transform in spin $N/2$ representation of $SU(2)_1$ acting on the coordinates (θ_1, ϕ_1) . Each zero-mode represents a distinct particle if viewed from the AdS space, which then should give rise to a distinct operator in the gauge theory. We can repeat exactly the same analysis for the \mathcal{B} -family, by exchanging (θ_1, ϕ_1) and (θ_2, ϕ_2) .

3. Quivers for $T^{1,1}/\Gamma$

Now we move on to the construction of the quiver gauge theory corresponding to the orbifold of $T^{1,1}$ by a discrete subgroup of $SU(2)_1$. We begin by the review of the property of the discrete subgroups of $SU(2)$.

3.1 A-D-E classification of $SU(2)$ subgroups

There are diverse mathematical objects which are classified by the pattern¹ A-D-E, and the earliest in history is the classification of the Platonic solids, or more precisely their

¹See e.g. the list in section 2.2 of [23].

		Γ_0	Γ	$ \Gamma $	p	q	r
		\mathbb{Z}_n	\mathbb{Z}_{2n+1}				
cyclic	A_{2n}	n/a	\mathbb{Z}_{2n+1}				
cyclic	A_{2n-1}	\mathbb{Z}_n	\mathbb{Z}_{2n}				
dihedral	D_{n+2}	\mathcal{D}_n	$\widehat{\mathcal{D}}_n$	$4n$	n	2	2
tetrahedral	E_6	\mathcal{T}	$\widehat{\mathcal{T}}$	24	3	3	2
octahedral	E_7	\mathcal{O}	$\widehat{\mathcal{O}}$	48	4	3	2
icosahedral	E_8	\mathcal{I}	$\widehat{\mathcal{I}}$	120	5	3	2

Table 1: Data of discrete subgroups of $SO(3)$ and $SU(2)$.

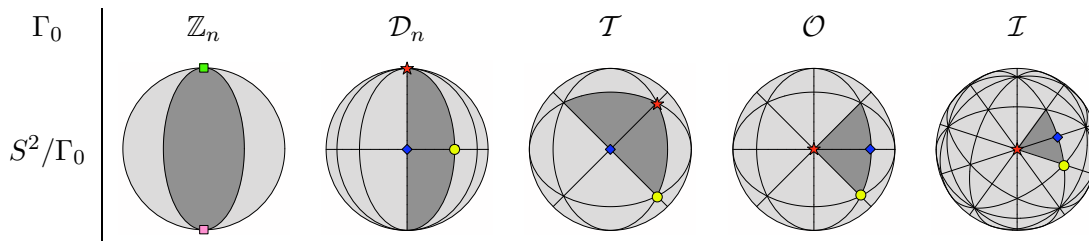

Figure 5: Form of S^2/Γ_0 . The fundamental region is shaded in dark grey. We used \mathbb{Z}_6 and \mathcal{D}_6 for illustration. For non-Abelian groups, the red star, the yellow circle, and the blue rhombus are the rotation axes of the generators a , b , c , respectively.

symmetry groups. They form discrete subgroups Γ_0 of $SO(3)$. There are two infinite families of cyclic and dihedral groups, and three exceptional cases of tetra-, octa- and icosahedral groups, which we denote by \mathbb{Z}_n , \mathcal{D}_n , \mathcal{T} , \mathcal{O} and \mathcal{I} , respectively. Their properties are summarized in table 1.

As an abstract group, each of the non-Abelian subgroup Γ_0 can be defined by the following relations about the generators a , b , c :

$$a^p = b^q = c^r = abc = 1, \tag{3.1}$$

where (p, q, r) is a triple of positive integers satisfying

$$\frac{1}{p} + \frac{1}{q} + \frac{1}{r} > 1. \tag{3.2}$$

Such a triple is called a Platonic triple, and there are one-to-one correspondence with Platonic triples and non-Abelian discrete subgroups of $SO(3)$. Furthermore, the fundamental domain S^2/Γ_0 has three orbifold singularities of the form \mathbb{C}/\mathbb{Z}_p , \mathbb{C}/\mathbb{Z}_q , \mathbb{C}/\mathbb{Z}_r ; see figure 5. More about classical aspects of these groups can be found in the beautiful textbook by Coxeter [24].

Any discrete subgroup Γ_0 of $SO(3)$ is the projection of a subgroup Γ of $SU(2)$ with $|\Gamma| = 2|\Gamma_0|$, which are called binary dihedral groups, the binary tetrahedral group, etc. Every non-Abelian finite subgroup of $SU(2)$ is obtained in this way. For Abelian subgroups, $\mathbb{Z}_n \subset SO(3)$ comes from $\mathbb{Z}_{2n} \subset SU(2)$, while $\mathbb{Z}_n \subset SU(2)$ for odd n , generated by $\text{diag}(e^{2\pi i/n}, e^{-2\pi i/n})$, does not arise from a subgroup of $SO(3)$ in this way.

The groups listed in table 1 are tagged with the types A , D and E . The Dynkin diagram can be assigned to each of the group in various ways, but the one most relevant

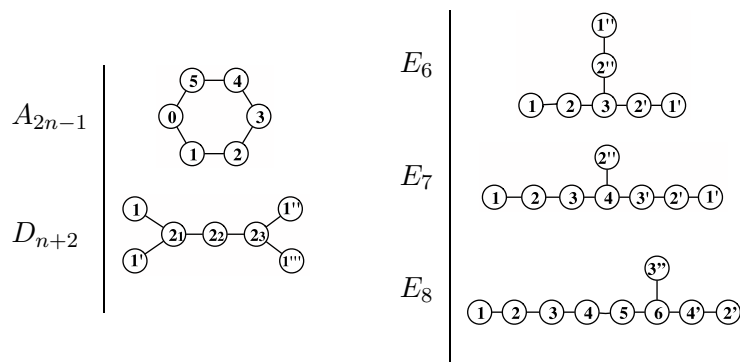

Figure 6: Diagrams formed by irreducible representations. We used A_5 and D_6 for illustration.

to us is the McKay correspondence. It goes as follows: for a discrete subgroup Γ of $SU(2)$, let ρ_s ($s = 1, \dots, n_\Gamma$) be its irreducible representations, and prepare n_Γ nodes associated to them. Γ has a standard two-dimensional representation ρ_2 as a subgroup of $SU(2)$, and it happens that the irreducible decomposition of $\rho_s \otimes \rho_2$ contains each of the irreducible representation at most once. Thus we can write

$$\rho_s \otimes \rho_2 = \bigoplus_{t \in S_s} \rho_t \quad (3.3)$$

using $S_s \subset \{1, \dots, n_\Gamma\}$. The fact that $\mathbf{2}$ is the conjugate representation of itself means $t \in S_s$ if and only if $s \in S_t$. The surprising correspondence found by McKay is that the graph of n_Γ points with edges drawn between s and t if $t \in S_s$ is one of the extended Dynkin diagrams of A-D-E type, see figure 6. For D_n and E_n , irreducible representations are labeled with their dimensions, and we put primes to distinguish different irreducible representations of the same dimension. The readers can find the character tables of these groups in appendix A.

One immediate consequence of (3.3) is that $d_s = \dim \rho_s$ satisfies

$$2d_s = \sum_{t \in S_s} d_t, \quad (3.4)$$

i.e. the vector (d_s) is the eigenvector of the Cartan matrix with eigenvalue 0. In a similar way, for any element $g \in \Gamma$, the vector of the characters $(\text{tr}_{\rho_s} g)$ is an eigenvector with the eigenvalue $2 - \text{tr}_2 g$.

Another important representation of Γ is the regular representation ρ_r which is $|\Gamma|$ dimensional: its orthonormal basis is given by e_g for $g \in \Gamma$ and the action of Γ is given by

$$\rho_r(h)e_g = e_{hg}. \quad (3.5)$$

A fundamental theorem of finite group theory states that the regular representation decomposes as

$$\rho_r = \bigoplus_{s=1}^{n_\Gamma} \rho_s^{\oplus d_s} \quad (3.6)$$

and thus

$$|\Gamma| = \sum_{s=1}^{n_\Gamma} d_s^2. \tag{3.7}$$

3.2 Geometry

$T^{1,1}/\Gamma$ is a smooth space with no orbifold singularity, because the action of $\Gamma \subset \text{SU}(2)_1$ to the coordinates (θ_1, ϕ_1, ψ) is topologically the group action of $\text{SU}(2)$ from the left of $S^3 \sim \text{SU}(2)$, and thus it has no fixed points in S^3 . One can also understand this fact using the Hopf fibration $S^3 \rightarrow S^2$. The action of $\text{SU}(2)_1$ to the S^2 parametrized by (θ_1, ϕ_1) is the usual rotation of $\text{SO}(3)$. Thus, for any element $g \in \text{SU}(2)_1$ which is not $\pm \mathbf{1}$, there are two points on S^2 fixed by g . At these fixed points, g acts as the translation of the coordinate ψ of the S^1 fiber by

$$\psi \rightarrow \psi + 4\pi/n \tag{3.8}$$

where n is the smallest nonzero integer such that $g^n = \mathbf{1}$.

As an orbifold without fixed points, the fundamental group is given by the orbifolding group itself, that is $\pi_1(T^{1,1}/\Gamma) = \Gamma$. Utilizing this, let us check that the orbifolding does not reduce the amount of supersymmetry preserved by the background. The covariantly constant spinor ψ is determined only up to an overall phase, and the supersymmetry is broken if there is a non-trivial phase $\alpha(g) \in \text{U}(1)$ after the parallel transport along the path $g \in \pi_1$,

$$g_*\psi = \alpha(g)\psi. \tag{3.9}$$

Here $g_*\psi$ is the spinor after the parallel transport. To show $\alpha(g) = 1$, one only needs to realize that one can define $\alpha(g)$ for arbitrary $g \in \text{SU}(2)$ by the pull-back. Then $\alpha : \text{SU}(2) \rightarrow \text{U}(1)$ must be a one-dimensional representation of $\text{SU}(2)$, which is automatically trivial.

3.3 Construction of the quiver

Let us now construct the dual quiver gauge theory for the Type IIB string on $T^{1,1}/\Gamma \times \text{AdS}_5$, where Γ is one of the discrete subgroup of $\text{SU}(2)_1$. Its moduli space should contain the N -th symmetric power of C/Γ , i.e. the conifold C orbifolded by Γ .

We follow the procedure given by Douglas and Moore [15] in the case of $\mathcal{N} = 2$ orbifold of \mathbb{C}^2 : to realize N D3-branes moving on C/Γ , we consider $\tilde{N} = N|\Gamma|$ D3-branes on C so that D3-branes occupy the points related by the action of Γ . Therefore, we start from the conifold gauge theory with two $\text{SU}(\tilde{N})$ gauge groups with four bifundamentals A^i and B^j . We label \tilde{N} rows and columns by the pair (k, g) where $k = 1, \dots, N$ and $g \in \Gamma$. The branch which concerns us is the one where A^i and B^j are all diagonal; we denote the diagonal entries by $a_{k,g}^i$ and $b_{k,g}^i$. Then we need to impose

$$a_{k,hg}^i = \rho_2(h)_j^i a_{k,g}^j, \quad b_{k,hg}^i = b_{k,g}^i \tag{3.10}$$

for all $h \in \Gamma$, so that the \tilde{N} branes are placed at the points related by $\Gamma \subset \text{SU}(2)_1$.

The conditions above can be enforced by demanding that

$$A_k^{i,l} = \rho_2(h)_j^i \rho_r(h) A_j^l \rho_r(h)^{-1}, \quad B_k^{i,l} = \rho_r(h) B_k^l \rho_r(h)^{-1}. \quad (3.11)$$

We omitted the indices for the regular representation to reduce the clutter. To be consistent, the generator X of the gauge transformations should also be restricted so that

$$X_k^l = \rho_r(h) X_k^l \rho_r(h)^{-1}. \quad (3.12)$$

To analyze further, we change the basis of the regular representation to the r.h.s. of (3.6), and replace the index $g \in \Gamma$ by the triple (s, α, a) , where $s = 1, \dots, n_\Gamma$ labels irreducible representations of Γ , $\alpha = 1, \dots, d_s$ labels d_s copies of ρ_s in ρ_r , and a is the index on which ρ_s acts. The equation (3.12) becomes

$$X_{k,s,\alpha}^{l,t,\beta} = \rho_s(h) X_{k,s,\alpha}^{l,t,\beta} \rho_t(h)^{-1} \quad (3.13)$$

and we omitted the indices for $\rho_{s,t}$. The solution is given by

$$X_{k,s,\alpha}^{l,t,\beta} = x_{k,\alpha}^{l,\beta} \delta_s^t \mathbf{1}_s. \quad (3.14)$$

via Schur's lemma. Here $\mathbf{1}_s$ is the identity matrix of the representation ρ_s . Thus each of the two $SU(\tilde{N})_{1,2}$ gauge groups is projected to the product of $SU(Nd_s)_{1,2}$ gauge groups, $s = 1, \dots, n_\Gamma$. In the same way, the field B^i is decomposed to the bifundamental fields B_s^i connecting $SU(Nd_s)_2$ to $SU(Nd_s)_1$. The $SU(2)_2$ global symmetry acting on \mathcal{B} -type fields remains unbroken by orbifolding.

The condition (3.11) for the field A is slightly more complicated: in the new basis it becomes

$$A_{k,s,\alpha}^{i,l,t,\beta} = \rho_2(h)_j^i \rho_s(h) A_j^l \rho_s(h)^{-1} \rho_t(h)^{-1}. \quad (3.15)$$

Again, Schur's lemma means the solution is given by

$$A_{k,s,\alpha,a}^{i,l,t,\beta,b} = a_{k,s,\alpha}^{l,t,\beta} P_a^{i,b} \quad (3.16)$$

for $s \in S_t$, and zero otherwise. Here $P_a^{i,b}$ is the projector from $\rho_2 \otimes \rho_t$ to the component ρ_s in (3.3). Thus, the field A^i is projected to the bifundamental fields $A_{s \rightarrow t}$ connecting $SU(Nd_s)_1$ and $SU(Nd_t)_2$ whenever the nodes s and t are connected in the Dynkin diagram.

The resulting quivers are depicted in figure 7. There, the $SU(Nd_s)_1$ gauge group is represented by a white circle with d_s inside, the $SU(Nd_t)_2$ gauge group by a black circle with d_t inside, $A_{s \rightarrow t}$ fields by black single arrows from a white circle to a black one, and finally B_s^i fields by red double arrows from a black circle to a white one. We call the fields $A_{s \rightarrow t}$ and B_s^i collectively as \mathcal{A} -type and \mathcal{B} -type fields,² respectively. The superpotential of the theory is quartic, coming from $\varepsilon_{ij} \varepsilon_{kl} \text{tr} A^i B^k A^j B^l$ of the unprojected $SU(N|\Gamma) \times SU(N|\Gamma)$ theory.

The structure of the quiver is quite simple; it consists of two extended Dynkin diagrams of the A-D-E type of the discrete subgroup used, connected to a ladder by double arrows

²We also denote baryonic operators constructed from \mathcal{A} -type and \mathcal{B} -type fields as \mathcal{A} -type and \mathcal{B} -type baryons. Do not confuse ‘ \mathcal{A} -type baryons’ with ‘baryons of \mathcal{A} -type quivers.’

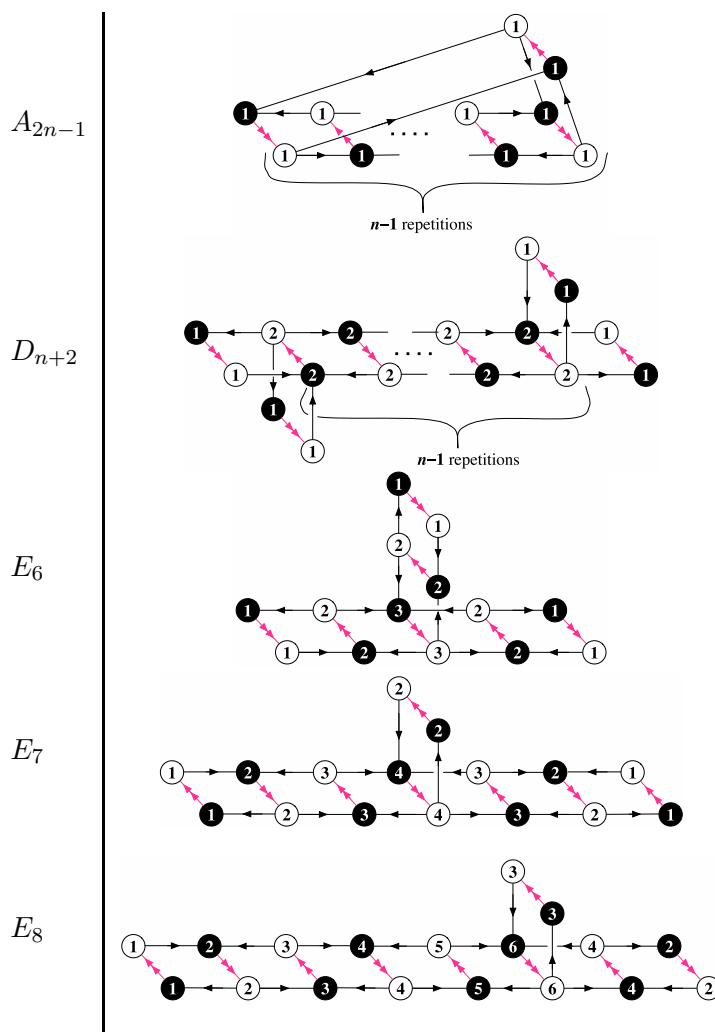

Figure 7: Quivers.

of \mathcal{B} -type fields. For $\Gamma = \mathbb{Z}_n$, this is equivalent to the so-called $Y^{n,0}$ quiver. An important property of each of the Dynkin sub-quiver formed by \mathcal{A} -type fields is that the direction of the arrows are alternating, i.e. the single black arrows at each nodes are all incoming or all outgoing. We call them alternating Dynkin quivers. This particular orientation of the arrows is known to be natural from the point of view of McKay correspondence [25]. Indeed, it can be realized by first classifying the nodes into two sets depending whether $-1 \in \text{SU}(2)$ is represented as $+1$ or -1 in the corresponding representation, and then by connecting the first set to the second by arrows.

3.4 Some checks of the correspondence

We constructed the quiver gauge theory to have N -th symmetric product of C/Γ as a branch of the moduli space, so it passes the first test that it should describe the motion of N D3-branes of C/Γ . Also, the quiver we obtained is free from cubic gauge anomalies

of the $SU(Nd_s)_{1,2}$ gauge groups as there are as many incoming arrows as outgoing ones at each node because of the relation (3.4).

Now we take the low-energy limit of the theory when all of the D3-branes are at the tip of the cone, which leads to the correspondence of the Type IIB string on $T^{1,1}/\Gamma \times AdS_5$ and the infrared limit of the quiver gauge theory of the last subsection. It is natural to assign the scaling dimension $3/4$ to all of the bifundamentals as was the case in the un-orbifolded conifold theory. Then the NSVZ beta function of each gauge group can be checked to vanish using the relation (3.4).

Next, the central charges calculated from the geometry and the gauge theory agree. Indeed, from the formula (2.6) we have

$$a = c = \frac{27}{64} N^2 |\Gamma| \tag{3.17}$$

since $\text{Vol}(T^{1,1}/\Gamma) = \text{Vol} T^{1,1}/|\Gamma|$. From the point of view of the gauge theory, there are $\sum_s d_s^2$ times as many vector multiplets, \mathcal{A} - and \mathcal{B} -type chiral multiplets with the same assignments of R -charges. Then, the central charges are $\sum_s d_s^2$ times those of the conifold theory, and thanks to the relation (3.7) it is equal to (3.17).

Finally, the internal global symmetry of both sides agree: the isometry $SU(2)_1 \times SU(2)_2 \times U(1)_\psi$ of $T^{1,1}$ is broken to $U(1) \times SU(2)_2 \times U(1)_\psi$ or $SU(2)_2 \times U(1)_\psi$ depending on whether Γ is Abelian or not. In the gauge theory, $SU(2)_2$ acting on B^i fields is left intact under the orbifold projection, and the same is true for $U(1)_R = U(1)_\psi$. As for $SU(2)_1$ symmetry acting on the A fields, there remains a $U(1)$ subgroup if $\Gamma = \mathbb{Z}_n$ by assigning the charge $+1$ to $A_{s \rightarrow s+1}$ and -1 to $A_{s \rightarrow s-1}$, whereas nothing remains as the symmetry if Γ is non-Abelian. The baryonic symmetry of the conifold theory, with the charge $+1$ for A fields and -1 for B fields, is inherited in the orbifolded theory by the same assignment of the charges, and it agrees with the geometry in that $\dim H^3(T^{1,1}/\Gamma, \mathbb{R}) = 1$.

4. Baryons on $T^{1,1}/\Gamma$

We have constructed, à la Douglas and Moore, the quiver gauge theory describing D3-branes probing the conifold orbifolded by a discrete subgroup Γ of its $SU(2)$ isometry. In the large N limit it should be the dual gauge theory of Type IIB string theory on $T^{1,1}/\Gamma \times AdS_5$, and we performed some preliminary checks of the correspondence. The checks we did so far were satisfied more or less by construction of the quiver. We now move on to the main topic of our paper, namely the study of the baryonic operators and of their realization as wrapped D3 branes.

We will exclude the subgroup $\mathbb{Z}_{2n-1} \subset SU(2)$ in the following analysis, because it does not include $-1 \in SU(2)$ and shows a quite different behavior compared to other subgroups. In any case, the orbifold of the conifold by \mathbb{Z}_{2n-1} is toric, whose baryonic operators are the subject of intense study by various groups [11–13], and will hopefully be treated elsewhere.

We also study only the baryonic operators which are constructed solely from \mathcal{A} -type bifundamentals, or those made solely of \mathcal{B} -type bifundamentals. It is mainly because of technical complexity of the analysis of baryons of mixed types, as can be inferred from

the analysis in the toric cases. We will find a quite intricate structure even in the reduced classes of operators which we will analyze in the following.

4.1 \mathcal{B} -type baryons

Let us wrap a D3-brane at fixed (θ_2, ϕ_2) . In the un-orbifolded case, the brane corresponds to the operator $\det B$ in the conifold gauge theory. Hence in the orbifolded case, the operator should be constructed solely from the \mathcal{B} -type fields in the quiver.

Here, the worldvolume is S^3/Γ . We can wrap multiple, say k of D3-branes at the same place, then we have the choice of the flat worldvolume gauge field in $U(k)$ [6, 16]. Since $\pi_1(S^3/\Gamma) = \Gamma$, the freedom in the Wilson lines is given by a k -dimensional representation of Γ , which decompose to the direct sum of irreducible representations ρ_s of Γ .

Hence there should be an operator \mathcal{B}_s in the gauge theory for each irreducible representation ρ_s . The motion along (θ_2, ϕ_2) needs to be quantized. For the trivial representation of Γ , it gives rise to the baryonic operator which transforms as the spin $N/2$ representation of $SU(2)_2$. For ρ_s with $d_s = \dim \rho_s > 1$, the moduli space of the center of mass is still S^2 , but we have d_s times as much five-form flux coupling to the worldvolume. Therefore it comes in the spin $Nd_s/2$ representation of $SU(2)_2$ global symmetry.

The scaling dimension of these operators \mathcal{B}_s can be fixed by the comparison with the un-orbifolded case. Recall that the scaling dimension is given by the mass of the wrapped D3-branes times the curvature radius of the AdS space. By the equations of motion of Type IIB string theory, it is clear that the curvature of the AdS space is the same for the $T^{1,1}/\Gamma$ theory with N units of flux and $T^{1,1}$ theory with $N|\Gamma|$ units of flux. In the latter case, the brane wrapped on S^3 parametrized by (θ_1, ϕ_1, ψ) corresponds to the operator $\det B$ with $\Delta = 3N|\Gamma|/4$. In the former, the brane wrapped on S^3/Γ has $1/|\Gamma|$ as much mass as that of the latter. Therefore, the gauge theory operator \mathcal{B}_s should have the dimension

$$\Delta(\mathcal{B}_s) = 3Nd_s/4. \tag{4.1}$$

In the following, the scaling dimension always appears with a factor of $3N/4$, so we define the weight w of an operator \mathcal{O} by

$$\Delta(\mathcal{O}) = (3N/4)w(\mathcal{O}). \tag{4.2}$$

Then $w(\mathcal{O}) = d_s$.

The gauge theory naturally reproduces this result. Indeed, since \mathcal{B} -type bifundamental fields are disconnected in the quiver diagram, any operator constructed solely out of \mathcal{B} -type fields are the product of the following operators

$$\det B_s^{i_1 \dots i_{Nd_s}} \equiv \varepsilon_{1s} \varepsilon_{2s} B_s^{i_1} \dots B_s^{i_{Nd_s}}, \tag{4.3}$$

where ε_{is} , $i = 1, 2$ are the epsilon symbols of $SU(Nd_s)_i$ gauge groups, and we omitted the gauge indices for brevity. It is easy to see that $\det B_s$ has weight $w(\det B_s) = d_s$, and comes in the spin $Nd_s/2$ representation of $SU(2)_2$ because two epsilon symbols symmetrize the indices i_1, \dots, i_{Nd_s} .

4.2 \mathcal{A} -type baryons

4.2.1 Geometry

Next, let us consider D3 branes wrapped on three-cycles at fixed (θ_1, ϕ_1) . The corresponding operator in the un-orbifolded case is $\det A$. Therefore the operators for these branes in the orbifolded case should be constructed out of the \mathcal{A} -type bifundamentals only.

If the coordinates (θ_1, ϕ_1) are generic, the only element in Γ which fixes these coordinates is -1 , which shifts the ψ coordinate halfway, $\psi \rightarrow \psi + 2\pi$. Thus we know the worldvolume topology is S^3/\mathbb{Z}_2 , and we have the choice of the worldvolume Wilson line which gives the phase ± 1 when one traverses the ψ coordinate. The weight of the corresponding operator is determined by repeating the previous argument, and is

$$w = |\Gamma|/2. \tag{4.4}$$

Let us denote operators of this kind collectively by \mathcal{A} .

The D3-brane can be moved along (θ_1, ϕ_1) preserving supersymmetry, and hence we need to quantize the motion along this direction. The moduli space of the D3-brane in this direction is S^2/Γ , which we presented in figure 5. S^2/Γ has orbifold singularities, and the D3-brane put at these points can decay into multiple D3-branes as we will see shortly. Therefore the quantization will be a delicate procedure; but if we neglect the subtlety, there is $N + 1$ zero modes. It is because its wavefunction should be a holomorphic section of a line bundle over S^2/Γ with $c_1 = N$, as was briefly reviewed in section 2. It is natural to suppose the correction to the number of the zero-modes will be $O(1)$ in the large N limit. Combined with the choice of the Wilson line along the ψ direction, we predict the existence of $2N + O(1)$ distinct operators which we collectively call \mathcal{A} , with weight given by (4.4).

Let us consider what happens if we put the D3-branes at one of the orbifold points of S^2/Γ . Suppose the subgroup fixing the point is $\mathbb{Z}_{2k} \subset \Gamma$. Then the S^1 fiber above is acted by the shift in the ψ direction

$$\psi \rightarrow \psi + 2\pi/k. \tag{4.5}$$

Thus, the length of the fiber is $1/k$ of that of the S^1 fiber over generic points of S^2/Γ , and a single D3-brane wrapped at a generic point of S^2/Γ can decay into k D3-branes when moved to the orbifold point.

The worldvolume is topologically S^3/\mathbb{Z}_{2k} , and as always we have $2k$ choices α of the Wilson line phase along the ψ direction which should satisfy $\alpha^{2k} = 1$ [6, 16]. Then our prediction for the gauge theory operators is that, for each of the orbifold points of S^2/Γ , there are $2k$ distinct operators of weight $w = |\Gamma|/(2k)$ where $2k$ is the order of the orbifold point. As discussed in section 3.1, there are two orbifold points with $k = n$ for $\Gamma = \mathbb{Z}_{2n}$ and there are three orbifold points with k given by one of (p, q, r) of the Platonic triple if Γ is non-Abelian.

4.2.2 Gauge theory

A quick inspection of the quiver diagram, figure 7, tells us that the \mathcal{A} -type bifundamentals form two disjoint sets of Dynkin diagrams, and each of the Dynkin diagram has the direction

of its arrows alternating in the sense that each node has all arrows connected to it either all incoming or all outgoing. The direction of arrows of one Dynkin diagram is the reverse of that of the other Dynkin diagram. Since the reversal of the arrows is a matter of a change in convention, it is clear that two Dynkin diagrams gives the same number of gauge-invariant operators of the same scaling dimension.

Thus, from the analysis of the geometry, we expect that each alternating Dynkin quiver gives, for each of the orbifold point of S^2/Γ of the form \mathbb{C}/\mathbb{Z}_k , k gauge-invariant operators of weight $|\Gamma|/(2k)$. It is a non-trivial mathematical prediction on the inter-relation among objects classified by A-D-E coming from the AdS/CFT correspondence, in that the Dynkin diagram of type Γ ‘knows’ how Γ acts on S^2 as a subgroup of $SU(2)$. Indeed, this mathematical statement is precisely what was proved in [17].

Let us now construct some baryonic operators: the quiver gauge theory was obtained by imposing the condition (3.11) on the conifold gauge theory with $SU(N|\Gamma|)^2$ gauge group, and therefore we can embed the \mathcal{A} -type bifundamental fields in the fields $A^{1,2}$ of the un-orbifolded gauge theory. We can then construct an \mathcal{A} -type baryon by forming the dibaryon

$$\det(\lambda_i A^i) \tag{4.6}$$

given a two-dimensional complex vector λ_i . The condition (3.11) on the matrices A^i means that λ_i, λ'_i related by the action of $g \in \Gamma \subset SU(2)$ defines the same operator, and obviously a scalar multiplication of λ_i does not matter either. Therefore the moduli space of such operators forms the space \mathbb{CP}^1/Γ .

It is a $N|\Gamma|$ -by- $N|\Gamma|$ matrix, and thus gives a weight- $|\Gamma|$ operator which is twice as much as the operator we would like to have. However, the $N|\Gamma|$ -dimensional space of Chan-Paton indices can be decomposed into the direct sum of two vector spaces V_{\pm} of dimension $N|\Gamma|/2$ where the element $-1 \in SU(2)_1$ of the global symmetry acts as ± 1 and that A^i is block-off-diagonal with respect to this decomposition. Furthermore, this decomposition is compatible with the action of the gauge group of the quiver, $G = \prod_s SU(d_s N)$, since $G \subset SU(|\Gamma|N)$ is defined as the subgroup which commutes with the action of Γ , see (3.12). Therefore the dibaryon (4.6) is a product of two gauge-invariant baryonic operators,

$$\det(\lambda_i A^i) = \mathcal{A}_{+\rightarrow-}(\lambda_i) \mathcal{A}_{-\rightarrow+}(\lambda_i), \tag{4.7}$$

each of weight $|\Gamma|/2$. Here, $\mathcal{A}_{\pm\rightarrow\mp}$ is the determinant of the part of $\lambda_i A^i$ which maps V_{\pm} to V_{\mp} . They give $O(N)$ distinct operators each. The precise number will be determined in section 7.

Next let us consider what happens when the vector λ_i is at an orbifold point of \mathbb{CP}^1/Γ , i.e. when λ_i is an eigenvector of $g \in \Gamma \subset SU(2)$ generating \mathbb{Z}_{2k} . We can assume λ^i has the eigenvalue $\alpha = \exp(2\pi i/(2k))$, and decompose the spaces V_{\pm} into the eigenspaces V_i of g where g acts as a scalar multiplication by α^i . We then have

$$V_+ = V_2 \oplus V_4 \oplus \dots \oplus V_{2k}, \quad V_- = V_1 \oplus V_3 \oplus \dots \oplus V_{2k-1}, \tag{4.8}$$

and the dimension of V_i is uniformly $|\Gamma|/(2k)$ since g acts as the permutation of the basis vectors of the regular representation.

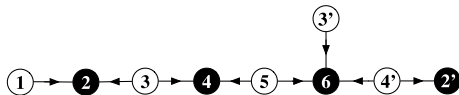

Figure 8: Alternating quiver for E_8 .

Now the condition (3.11) means the matrix $\lambda_i A^i$ maps the block V_i to V_{i+1} ; the dibaryon (4.7) further decomposes into the product

$$\begin{aligned} \mathcal{A}_{+\rightarrow-} &= \mathcal{A}_{0\rightarrow 1} \mathcal{A}_{2\rightarrow 3} \cdots \mathcal{A}_{-2\rightarrow -1}, \\ \mathcal{A}_{-\rightarrow+} &= \mathcal{A}_{1\rightarrow 2} \mathcal{A}_{3\rightarrow 4} \cdots \mathcal{A}_{-1\rightarrow 0} \end{aligned} \quad (4.9)$$

where $\mathcal{A}_{i\rightarrow i+1}$ is the determinant of the part of $\lambda_i A^i$ mapping V_i to V_{i+1} . Each $\mathcal{A}_{i\rightarrow i+1}$ has weight $|\Gamma|/(2k)$, and there are $2k$ of them. In this way we constructed the baryonic operators which realizes the expectation from the AdS/CFT correspondence; we call these operators “fractional dibaryons.”

However, the analysis of the geometry of $T^{1,1}/\Gamma$ predicts not just the existence of the operators with the prescribed weight; it also predicts they are the only baryonic operators. We continue our discussion in the new section because, as we will see, the confirmation of the prediction requires a quite lengthy analysis.

5. \mathcal{A} -type baryons on $T^{1,1}/\Gamma$: direct analysis

In the previous section we found that there are \mathcal{A} -type baryonic operators of the alternating Dynkin quivers with weight predicted by the geometry. The aim of this section is to construct such operators explicitly and to show that any \mathcal{A} -type baryon can be written as a polynomial of them. To this aim, we put geometric intuition aside for a while, and consider the problem purely from the viewpoint of the quiver gauge theory. Section 5 and section 6 provide two mostly independent methods of classifying these baryonic operators, and can be read in either order according to the reader’s taste.

5.1 Some examples

Let us first construct some baryonic operators on the alternating Dynkin quiver. We use the most interesting icosahedral group $\widehat{\mathcal{I}} = E_8$ as the example. The analysis of the geometry of S^2/\mathcal{I} told us that the operator with the smallest weight is the one with weight $12 = 120/(2 \cdot 5)$. What does it look like?

The subquiver we are concerned is depicted in figure 8. Let us try to imitate the construction of the dibaryons. We take the N -th power of the field $A_{1\rightarrow 2}$ and contract the N indices of $SU(N)$ by the epsilon symbol $\varepsilon_{(1)}$ of $SU(N)$. Now we have an operator of the form

$$\varepsilon_{(1)}^{i_1 \cdots i_N} A_{1\rightarrow 2_{i_1}}^{j_1} \cdots A_{1\rightarrow 2_{i_N}}^{j_N} \quad (5.1)$$

The indices j_1 to j_N for $SU(2N)$ need to be contracted using the epsilon symbol $\varepsilon^{(2)}$ for $SU(2N)$, which has $2N$ indices. Thus, contrary to the case of the dibaryons, the

bifundamental field $A_{1 \rightarrow 2}$ alone cannot make a gauge-invariant operator. We need to contract the extra N indices by using N of the field $A_{3 \rightarrow 2}$; now we have an operator of the form

$$\varepsilon_{(1)}^{i_1 \dots i_N} A_{1 \rightarrow 2}^{j_1} \dots A_{1 \rightarrow 2}^{j_N} \varepsilon_{j_1 \dots j_N j_{N+1} j_{2N}}^{(2)} A_{3 \rightarrow 2}^{k_1} \dots A_{3 \rightarrow 2}^{k_N} \quad (5.2)$$

It is not yet gauge invariant, and we need to continue this procedure. The expression for the operator becomes increasingly cumbersome, so we abbreviate it as

$$\varepsilon_{(1)}(A_{1 \rightarrow 2})^N \varepsilon^{(2)}(A_{3 \rightarrow 2})^N, \quad (5.3)$$

where the gauge indices are suppressed and the contraction against epsilon symbols are understood.

Now we see that it becomes gauge-invariant at the stage

$$\mathcal{P}_1 = \varepsilon_{(1)}(A_{1 \rightarrow 2})^N \varepsilon^{(2)}(A_{3 \rightarrow 2})^N \varepsilon_{(3)}(A_{3 \rightarrow 4})^{2N} \times \varepsilon^{(4)}(A_{5 \rightarrow 4})^{2N} \varepsilon_{(5)}(A_{5 \rightarrow 6})^{3N} \varepsilon^{(6)}(A_{3' \rightarrow 6})^{3N} \varepsilon_{(3')} \quad (5.4)$$

which has weight 12, as was predicted from the geometry! We can also construct a baryonic operator starting from the $A_{3 \rightarrow 2}$ field, which results in the operator

$$\mathcal{P}_2 = \varepsilon^{(2)}(A_{3 \rightarrow 2})^{2N} \varepsilon_{(3)}(A_{3 \rightarrow 4})^N \varepsilon^{(4)}(A_{5 \rightarrow 4})^{3N} \varepsilon_{(5)}(A_{5 \rightarrow 6})^{2N} \varepsilon^{(6)}(A_{4' \rightarrow 6})^{4N} \varepsilon_{(4')}. \quad (5.5)$$

Its weight is also 12. To verify the prediction from the geometry, we need to find three other operators with weight 12, and to check that they are the only ones.

Let us introduce another notation for the baryons thus constructed: we introduce a vector $(m_i)_{i=1, \dots, s}$ where m_i is the number of the epsilon symbols used for the gauge group $SU(d_i N)$. We call it the ‘dimension vector’ of the operator for the reason we will see in section 6. When we write down the dimension vector explicitly, we put the numbers in the form of the Dynkin diagram, e.g. for the operators (5.4) and (5.5), they are

$$v_1 = \begin{array}{cccccccc} & & & & 1 & & & \\ & & & & | & & & \\ & & & & 1 & 1 & 1 & 1 & 1 & 0 & 0 \end{array}, \quad v_2 = \begin{array}{cccccccc} & & & & & & 0 & & & & \\ & & & & & & | & & & & \\ & & & & & & 0 & 1 & 1 & 1 & 1 & 1 & 0 \end{array}. \quad (5.6)$$

If we hypothetically enlarge the i -th gauge group from $SU(d_i N)$ to $U(d_i N)$, the vector (Nm_i) gives the charge vector of the baryonic operator under the $U(1)$ parts of the gauge groups of the nodes. These $U(1)$ symmetries are anomalous, yet useful in classifying the baryonic operators of the theory.³

Now it is easy to see that \mathcal{P}_1 and \mathcal{P}_2 are the only operators with dimension vector v_1 and v_2 , respectively. The dimension vector of $(\mathcal{P}_1)^2$ is $2v_1$, and the analysis of the geometry of $T^{1,1}/\Gamma$ predicts that it is the only operator with this dimension vector. It is not obvious from the point of view of the gauge theory. Indeed, an operator with dimension vector $2v_1$ has the form

$$\varepsilon_{(1)} \varepsilon_{(1)}(A_{1 \rightarrow 2})^{2N} \varepsilon^{(2)} \varepsilon^{(2)}(A_{3 \rightarrow 2})^{2N} \dots, \quad (5.7)$$

³The importance of anomalous baryonic symmetries was pointed out to the authors by A. Hanany.

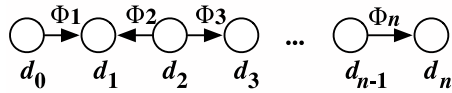

Figure 9: Linear alternating quiver.

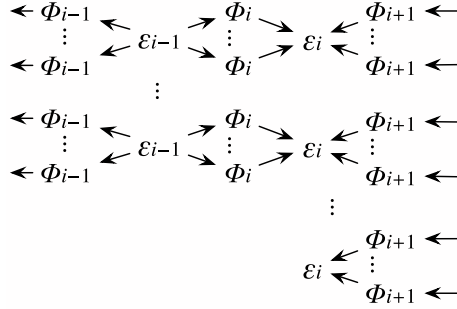

Figure 10: Untangled operator .

and there seems to be the choice of how many $A_{1 \rightarrow 2}$ fields contract the indices of the first $\varepsilon_{(1)}$ and of the first $\varepsilon^{(2)}$, and of the first $\varepsilon_{(1)}$ and of the second $\varepsilon^{(2)}$, etc. If the prediction from the AdS/CFT correspondence is true, these multitude of operators should be proportional to each other. Similar choices in the contraction of indices arise for each bifundamental fields, and in total there are milliards of possibilities in the way of contraction. Therefore we need powerful methods to ‘untangle’ these complicated contraction of indices of epsilon symbols, which we develop in section 5.2 and 5.3.

5.2 Untangling procedure

In this section we explain how one can transform baryonic operators of the linear alternating quiver, see figure 9, to a standard ‘untangled’ form. There, the gauge group of the i -th node is $SU(d_i)$, and there is a bifundamental Φ_i between $SU(d_{i-1})$ and $SU(d_i)$ with the index structure specified by the direction of the arrow, i.e. all the indices of $SU(d_{\text{even}})$ transforms as anti-fundamental, and those of $SU(d_{\text{odd}})$ as fundamental. As a further technical assumption, we demand that $d_i \leq d_{i+1}$ is satisfied for arbitrary i .

Suppose the baryonic operator contains m_i epsilon symbols for $SU(d_i)$. In order to specify the contraction of indices, we denote the α -th epsilon symbol of $SU(d_i)$ by $\varepsilon_i^{(\alpha)}$, $\alpha = 1, \dots, m_i$. The standard ‘untangled’ form of the operator is such that any bifundamental field Φ_i is contracted against $\varepsilon_{i-1}^{(\alpha)}$ and $\varepsilon_i^{(\alpha)}$ with the same α , see figure 10. The arrows in this figure represent the contraction of gauge indices.

First, for any given baryonic operator, all the $SU(d_{i-1})$ and $SU(d_i)$ indices of Φ_i ’s in the operator are contracted against invariant tensors ε_{i-1} and ε_i respectively, and the remaining indices of ε_{i-1} and ε_i are contracted with those of Φ_{i-1} and Φ_{i+1} as the left hand side of figure 11. The region with the question mark ‘?’ in this figure is an arbitrary

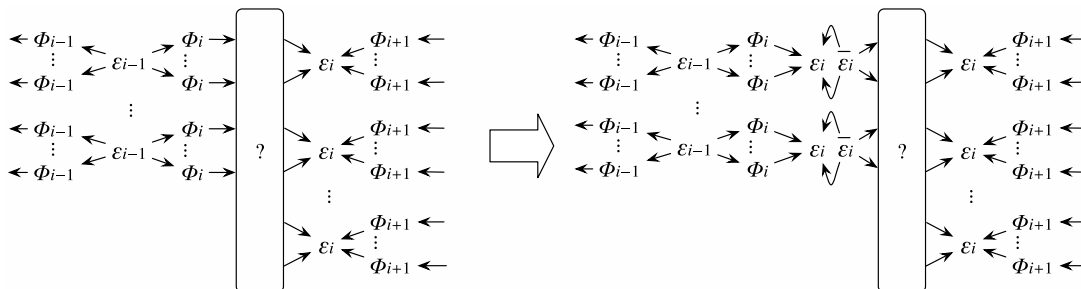

Figure 11: Untangling procedure.

permutation of arrows. We can simplify this by using the identity

$$\varepsilon^{a_1 \dots a_k c_1 \dots c_{d-k}} \bar{\varepsilon}_{b_1 \dots b_k c_1 \dots c_{d-k}} \propto \delta_{[b_1}^{[a_1} \dots \delta_{b_k]}^{a_k]}, \quad (5.8)$$

where ε is the epsilon symbol which can be used to contract the bifundamentals in the quiver, and $\bar{\varepsilon}$ is the one which cannot be. Suppose k of Φ_i s are contracted with $\varepsilon_{i-1}^{(\alpha)}$. Since the $SU(d_i)$ indices of these Φ_i are then completely antisymmetric, we can insert $\delta_{[b_1}^{[a_1} \dots \delta_{b_k]}^{a_k]}$ for $SU(d_i)$ there, and we replace the Kronecker deltas by two epsilon symbols using (5.8). That is, we rewrite the relevant part as follows:

$$(\varepsilon_{i-1}^{(\alpha)})^{a_1 \dots a_k} (\Phi_i)_{a_1}^{i_1} \dots (\Phi_i)_{a_k}^{i_k} \propto (\varepsilon_{i-1}^{(\alpha)})^{a_1 \dots a_k} (\Phi_i)_{a_1}^{j_1} \dots (\Phi_i)_{a_k}^{j_k} \varepsilon_{j_1 \dots j_k c_1 \dots c_{d-k}} \bar{\varepsilon}^{i_1 \dots i_k c_1 \dots c_{d-k}}, \quad (5.9)$$

see the right hand side of Fig 11.

If $m_{i-1} \leq m_i$, we insert m_{i-1} pairs of ε_i and $\bar{\varepsilon}_i$ for all $\varepsilon_{i-1}^{(\alpha)}$, $\alpha = 1, \dots, m_i$. Then, we use (5.8) again to eliminate the newly-introduced $\bar{\varepsilon}_i$ against ε_i which is originally in the baryonic operators from the beginning. The elimination turns them into antisymmetrized product of Kronecker deltas, and at this stage, the indices of $SU(d_i)$ of the Φ_i s which are contracted with $\varepsilon_{i-1}^{(\alpha)}$ are contracted with one and the same ε_i as figure 10. We rename this ε_i as $\varepsilon_i^{(\alpha)}$. We eliminate all of $\bar{\varepsilon}$'s in this way, and the result is now in the standard, ‘untangled’ form. We call this procedure as the ‘untangling of Φ_i at $SU(d_i)$ ’.

If $m_{i-1} > m_i$, the operator vanishes if $d_{i-2} < d_{i-1}$, or contains $\det \Phi_{i-1}$ as a factor if $d_{i-2} = d_{i-1}$. Indeed, we can exchange the roles of $SU(d_{i-1})$ and $SU(d_i)$ in the discussion above and introduce m_i pairs of $\bar{\varepsilon}_{i-1} \varepsilon_{i-1}$ for each $\varepsilon_i^{(\alpha)}$. After the elimination of newly introduced $\bar{\varepsilon}_{i-1}$, $m_i - m_{i-1}$ of ε_{i-1} have their indices all contracted against Φ_{i-1} , not against any Φ_i . If $d_{i-2} < d_{i-1}$, such an operator vanishes from the rank condition because Φ_{i-1} is a $d_{i-2} \times d_{i-1}$ matrix. If $d_{i-2} = d_{i-1}$, we can show that it contains $\det \Phi_{i-1}$ as a factor by untangling of Φ_i at $SU(d_i)$.

Similarly, if $d_i = d_{i+1}$ and $m_{i-1} < m_i$, the untangling of Φ_i at $SU(d_i)$ makes all the indices of $m_i - m_{i-1}$ ε_i to contract against Φ_{i+1} . Then, untangling of Φ_{i+1} at $SU(d_{i+1})$ produces $m_i - m_{i-1}$ factors of $\det \Phi_{i+1}$ from the original operator.

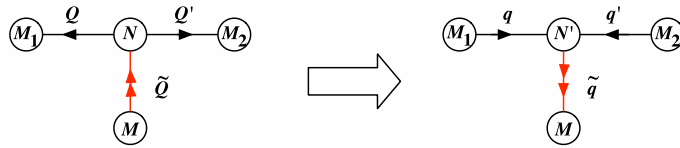

Figure 12: Seiberg duality at one of the nodes.

5.3 Action of the Seiberg duality

In this section we study the action of the Seiberg duality [26] on our quiver theory.⁴ Let us first consider the application of the duality at one of the nodes, see figure 12. We use a slightly general setup where $M \neq N$. The subtheory we consider has $SU(N)$ as the gauge group, and we treat $SU(M_{1,2})$ and $SU(M)$ as the global symmetry group. We name the bifundamental fields as in the figure. We assume $2M = M_1 + M_2$ so that the gauge anomaly vanishes. Then the $SU(N)$ gauge group has effectively $2M$ flavors, and the dual theory has $SU(N')$ with $N' = 2M - N$ as the gauge group. The arrows are reversed, since the representation of the dual quarks under the global symmetry is the complex conjugate of the original ones. There are extra meson fields in the dual theory, but we are more interested in the baryons, so let us discuss them first.

It is known that the baryons in the $SU(N_c)$ theory with N_f flavors Q_i, \tilde{Q}_i and the dual $SU(N'_c = N_f - N_c)$ theory with q^i, \tilde{q}^i are related by the rule

$$Q_{i_1} \cdots Q_{i_{N_c}} \varepsilon_{(N_c)} = \varepsilon_{i_1 i_2 \dots i_{N_f}} q^{i_{N_c+1}} \cdots q^{i_{N_f}} \varepsilon_{(N'_c)}, \quad (5.10)$$

where $\varepsilon_{(X)}$ and $\varepsilon^{(X)}$ are the epsilon symbols of $SU(X)$ theory with all indices up or down, respectively, and we omitted the gauge indices for $SU(N_c)$ and $SU(N'_c)$ for simplicity. Then, if we decompose the global symmetry $SU(N_f)$ to $SU(M_1) \times SU(M_2)$, we find the correspondence

$$Q^k \varepsilon^{(N)} Q'^{N-k} = \varepsilon^{(M_1)} q^{M_1-k} \varepsilon_{(N')} q'^{M_2+k-N} \varepsilon^{(M_2)}. \quad (5.11)$$

This equivalence of baryons of two quivers with opposite orientation of arrows has been known in mathematical literature for twenty years [27].

Now let us perform the Seiberg duality on our quiver gauge theory, simultaneously for all of the white nodes. Then we arrive at the quiver with all arrows reversed compared to the original theory. In our conformal case we have $N = M$, so that $N' = N$. It is easy to see that the meson fields can be integrated out to give back the purely quartic superpotential formed by the dual quarks, as was the case in the conifold theory. Note that it is a matter of convention which of the two N -dimensional representations of $SU(N)$ one calls the fundamental representation, so we are back at the original theory. Under this self-duality, the baryons are transformed non-trivially. Indeed, using (5.11) repeatedly, the dimension vector m'_i of the transformed baryon is given by the dimension vector m_i of the

⁴The authors would like to thank I. Klebanov for his suggestion to study the Seiberg duality acting on the baryonic operators.

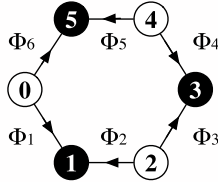

Figure 13: Alternating quiver for \mathbb{Z}_6 .

5.4.1 Cyclic groups \mathbb{Z}_{2n}

Let us label the gauge groups as $SU(N)_0, SU(N)_1, \dots, SU(N)_{2n-1}$, and the bifundamental connecting $SU(N)_i$ and $SU(N)_{i+1}$ as Φ_i . We identify the index i of the gauge group modulo $2n$. See the example in figure 13 for $\Gamma = \mathbb{Z}_6$. Here, the circle with a number i in it denotes the gauge group $SU(N)_i$.

Suppose we have an operator with dimension vector m_i , i.e. a gauge-invariant operator which is constructed by contracting the gauge indices of bifundamental fields by m_i epsilon symbols ε_i for $SU(N)_i$. We first show that the operator contains a factor of a dibaryon $\det \Phi_i$ if not all of m_i are equal. Indeed, then, there is an integer j such that $m_{j-1} < m_j$. Untangling Φ_j at $SU(N)_j$, we find $m_j - m_{j-1}$ epsilon symbols are contracted with Φ_{j+1} only, not at all with Φ_j . Untangling Φ_{j+1} at $SU(N)_{j+1}$ then makes $(\det \Phi_{j+1})^{m_j - m_{j-1}}$ factored out of the original operator.

Thus we first find $2n$ dibaryons $\det \Phi_i$, $i = 1, 2, \dots, 2n$ as a part of the generators of the baryonic operators. The first candidates of operators which cannot be written as their polynomial should have $m_1 = m_2 = \dots = m_{2n} = 1$ from the discussion above. We can write down $N - 1$ kinds of such gauge-invariant operators as follows:

$$\mathcal{O}_k = \varepsilon_0(\Phi_1)^k \varepsilon_1(\Phi_2)^{N-k} \varepsilon_2(\Phi_3)^k \dots (\Phi_{2n-1})^k \varepsilon_{2n-1}(\Phi_{2n})^{N-k}, \quad (5.15)$$

where $k = 1, 2, \dots, N - 1$. They are all of weight $n = |\Gamma|/2$.

Combining the results so far, we have found $2n$ generators of weight 1 and $N - 1$ generators of weight n , which precisely matches with the prediction from the geometry of $T^{1,1}/\mathbb{Z}_{2n}$ we discussed in section 4.2.1. We can show that any operator of the higher weight can be written as a polynomial of these generators using a careful application of untangling, which we will discuss in appendix C. We will derive the same fact using the theory of quiver representations in section 6.4.

5.4.2 Dihedral groups $\widehat{\mathcal{D}}_n$

We call the gauge groups as $SU(N), SU(N)', SU(N)'', SU(N)''', SU(2N)_1, SU(2N)_2, \dots,$ and $SU(2N)_{n-1}$. We have bifundamentals U connecting $SU(N)$ and $SU(2N)_1$, V connecting $SU(N)'$ and $SU(2N)_1$, W connecting $SU(N)''$ and $SU(2N)_{n-1}$, Z connecting $SU(N)'''$ and $SU(2N)_{n-1}$; we also have bifundamentals Φ_i connecting $SU(N)_i$ and $SU(N)_{i+1}$ for $i = 1, 2, \dots, n - 2$. See the example $\widehat{\mathcal{D}}_4$ depicted in figure 14. There, a circle with $1'$ in it denotes the $SU(N)'$ gauge group, a circle with 2_2 in it the gauge group $SU(2N)_2$, and so on.

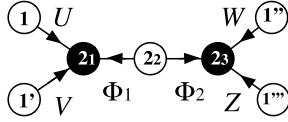

Figure 14: Alternating quiver for $\widehat{\mathcal{D}}_4$.

One can construct n gauge-invariant operators $\mathcal{P}_{1,\dots,n}$ of weight 2 as follows:

$$\mathcal{P}_1 = \varepsilon_N U^N \varepsilon_{2N,1} V^N \varepsilon_{N'}, \quad \mathcal{P}_i = \det \Phi_{i-1}, \quad \mathcal{P}_n = \varepsilon_{N''} W^N \varepsilon_{2N,n-1} Z^N \varepsilon_{N'''}, \quad (5.16)$$

and $i = 2, \dots, n-1$. Here, $\varepsilon_{2N,i}$ is the epsilon symbol of $SU(2N)_i$ and $\varepsilon_{N'}$ is that for $SU(N)'$, etc. We omitted the gauge indices for brevity, but it is clear that there is only one way of contracting the indices.

Let us take a gauge-invariant operator \mathcal{O} with dimension vector $(m, m', m'', m'''; \{m_i\})$ where m' is the number of the epsilon symbols for $SU(N)'$ etc., and m_i is the number of the epsilon symbols for $SU(2N)_i$. We first show that some of \mathcal{P}_i can be factored out of \mathcal{O} unless m_i is all equal. Indeed, if $m_1 > m_2$, we untangle Φ_1 at $SU(2N)_1$ to find that the indices of at least $m_1 - m_2$ epsilon symbols are contracted against only U or V , which inevitably leads to $m_1 - m_2$ factors of \mathcal{P}_1 . Similarly, we find $m_{n-1} - m_{n-2}$ factors of \mathcal{P}_n if $m_{n-1} > m_{n-2}$. If neither is the case, there should be i in the range $1 < i < n-1$ such that $m_i > m_{i+1}$ or $m_{i-1} < m_i$. The untangling then yields $m_i - m_{i+1}$ factors of $\det \Phi_{i-1}$ or $m_i - m_{i-1}$ factors of $\det \Phi_{i+1}$, respectively.

In the following we assume $m_i = \mu$ for all $1 \leq i \leq n-2$. Next we note that if an operator \mathcal{O} is decomposable if $m + m' \neq \mu$. It can be proved by taking the Seiberg dual at $SU(N)$, $SU(N)'$ and the nodes with the same color. Then the resulting operator \mathcal{O}' has $m_1 \neq m_2$ because

$$m_1(\mathcal{O}') = m + m' + m_2 - m_1 \neq \mu, \quad m_2(\mathcal{O}') = m_2(\mathcal{O}) = \mu. \quad (5.17)$$

Thus we can apply the preceding argument to show it decomposes.

Now let us analyze the operator with $m_i = 1$ for all $1 \leq i \leq n-1$. It is indecomposable if we have $(m, m, m', m'') = (1, 0, 1, 0)$, $(1, 0, 0, 1)$, $(0, 1, 1, 0)$ or $(0, 1, 0, 1)$, which lead to four operators

$$\mathcal{Q}_1 = U^N (\Phi_1)^N \cdots (\Phi_{n-2})^N W^N, \quad \mathcal{Q}_2 = V^N (\Phi_1)^N \cdots (\Phi_{n-2})^N Z^N \quad (5.18)$$

$$\mathcal{R}_1 = U^N (\Phi_1)^N \cdots (\Phi_{n-2})^N Z^N, \quad \mathcal{R}_2 = V^N (\Phi_1)^N \cdots (\Phi_{n-2})^N W^N \quad (5.19)$$

where the contraction of the indices against one epsilon symbol for each gauge group is understood. They all have weight n .

Next let us analyze the operator with $m_i = 2$ for all $1 \leq i \leq n-1$. We first show that it decomposes if $(m, m') = (2, 0)$. Indeed, we can apply the untangling procedure repeatedly, starting by W and Z at $SU(2N)_{n-1}$, then for Φ_{n-2} at $SU(2N)_{n-2}$, \dots and finally for U at $SU(N)_1$, which makes the operator proportional to either \mathcal{Q}_1^2 or $\mathcal{Q}_1 \mathcal{R}_1$. Similar arguments

can be made for the case $(m, m') = (0, 2)$, etc. Therefore, to be indecomposable, we need to have $m = m' = m'' = m''' = 1$.

These operators are automatically of weight $2n$. Now we apply the untangling procedure, starting from Z and W at $SU(2N)_{n-1}$, then for Φ_{n-2} at $SU(2N)_{n-2}$, all the way to Φ_1 at $SU(2N)_1$. Then they are combined into the following parts which only have $SU(2N)_1$ indices:

$$\mathcal{W}^{a_1 \dots a_N} = \varepsilon^{a_1 \dots a_N c_1 \dots c_N} (\Phi_1)_{c_1 \dots c_N}^N \varepsilon_2 (\Phi_2)^N \dots (\Phi_{n-2})^N \varepsilon_{n-2} W^N \varepsilon_{N''}, \quad (5.20)$$

$$\mathcal{Z}^{a_1 \dots a_N} = \varepsilon^{a_1 \dots a_N c_1 \dots c_N} (\Phi_1)_{c_1 \dots c_N}^N \varepsilon_2 (\Phi_2)^N \dots (\Phi_{n-2})^N \varepsilon_{n-2} Z^N \varepsilon_{N'''}. \quad (5.21)$$

Therefore the baryonic operator is of the form

$$\mathcal{O}_k = \mathcal{U}_{a_1 \dots a_k b_1 \dots b_{N-k}} \mathcal{V}_{c_1 \dots c_{N-k} d_1 \dots d_k} \mathcal{W}^{a_1 \dots a_k c_1 \dots c_{N-k}} \mathcal{Z}^{b_1 \dots b_{N-k} d_1 \dots d_k}, \quad (5.22)$$

with $k = 1, 2, \dots, N - 1$, where

$$\mathcal{U}_{a_1 \dots a_N} = \varepsilon_N (U^N)_{a_1 \dots a_N}, \quad \mathcal{V}_{a_1 \dots a_N} = \varepsilon_{N'} (V^N)_{a_1 \dots a_N}. \quad (5.23)$$

We omitted the gauge indices other than that of $SU(2N)_1$ to reduce the clutter. We will show in appendix D that a certain linear combination of them is decomposable for $N > 1$. We will also see that the remaining $N - 2$ of them are linearly independent in section 7.

Summarizing, we found that there are n operators \mathcal{P}_i with weight two and four operators $\mathcal{Q}_{1,2}$ and $\mathcal{R}_{1,2}$ with weight n . We additionally found order N of operators with weight $2n$. This spectrum is as it should be from the analysis of the geometry of $T^{1,1}/\mathcal{D}_n$.

We can show that any gauge-invariant operator can be written as a polynomial of the operators found above using the untangling procedure, for the detail see appendix C. We also see the same result can be derived using the structure of quiver representations in the next section.

6. Baryonic operators and quiver representations

In the last section we performed a direct analysis of the baryonic operators of the alternating Dynkin quiver, by the technique of the untangling of epsilons and by the application of the Seiberg duality. We studied the operators for A - and D -type subgroups, but the classification became quite formidable for other cases. In this section we will take an indirect approach utilizing the mathematical theory of quiver representations. Our general strategy is the following. We first show that the baryonic operators are spanned by the generalized determinants, defined in section 6.1. Then in section 6.2 we will see that each generalized determinant operator can be associated with a representation of the quiver. It reduces the enumeration of baryonic operators to the study of stably indecomposable representations of the quiver. We quote the theorem of Kac in section 6.3 which accomplishes the task for the extended Dynkin quivers. We apply the theorem to our gauge theory in section 6.4 to confirm the prediction of the number of baryonic operators from the geometry of $T^{1,1}/\Gamma$.

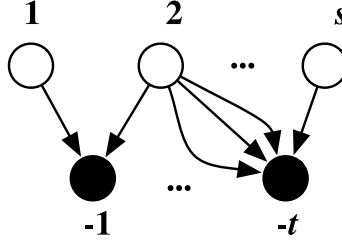

Figure 15: Bipartite quiver.

6.1 Generalized determinants

We first describe the baryonic operators which can be defined as the determinant of a big matrix constructed from the bifundamental fields. They can be defined for arbitrary bipartite quivers, i.e. quivers whose nodes can be divided into two classes, say white and black, and all the arrows are from a white node to a black node, see figure 15. Let us label the white nodes by $i = 1, \dots, s$ and the black nodes by $i = -1, \dots, -t$. Let us label the arrows by $a = 1, \dots, u$ and denote the nodes of the tail and the head of the i -th arrow by $t(a)$ and $h(a)$, respectively.

Now let us assign gauge groups $SU(d_i)$ to the nodes and bifundamental fields Φ_a to the arrows $a = 1, \dots, u$. Φ_a has the index structure $\Phi_{a\beta}^\alpha$ where $SU(d_{h(a)})$ and $SU(d_{t(a)})$ act on the indices $\alpha = 1, \dots, d_{h(a)}$ and $\beta = 1, \dots, d_{t(a)}$ as the fundamental and as the anti-fundamental representation, respectively.

The fundamental theorem of the classical invariant theory states that the only way of making gauge-invariant operators out of a monomial of the bifundamental fields

$$\prod_a \Phi_a^{n_a} \quad (6.1)$$

is to contract their indices against the epsilon tensors of the gauge groups. Let m_i be the number of the epsilon symbols used for the i -th gauge group, which should satisfy

$$m_i d_i = \sum_{t(a)=i} n_a \quad (6.2)$$

for each $i > 0$, and a similar expression for each $i < 0$. It follows that

$$\sum_{i>0} m_i d_i = \sum_{i<0} m_i d_i = \sum_a n_a \equiv w. \quad (6.3)$$

Any gauge invariant operator with prescribed n_a is a linear combination of the operators

$$\underbrace{\varepsilon_1 \cdots \varepsilon_1}_{m_1} \cdots \underbrace{\varepsilon_s \cdots \varepsilon_s}_{m_s} \underbrace{\varepsilon_{-1} \cdots \varepsilon_{-1}}_{m_{-1}} \cdots \underbrace{\varepsilon_{-t} \cdots \varepsilon_{-t}}_{m_{-t}} \prod_a \Phi_a^{n_a} \quad (6.4)$$

with various ways of contracting indices. Here ε_i is the epsilon tensor of the i -th gauge group. We call the vector (m_i) of the number of the epsilon symbols the dimension vector of the operator. The origin of the somewhat unnatural name will be explained later.

To facilitate the specification of the way of contraction, let us label each of m_i epsilon tensors of $SU(d_i)$ as $\varepsilon_i^{(k)}$ with $k = 1, \dots, m_i$. Then the contraction is fully specified by giving for each arrow a the numbers $n_{a_l}^k$ of bifundamentals Φ_a connecting $\varepsilon_{h(a)}^{(k)}$ and $\varepsilon_{t(a)}^{(l)}$. We denote the operator as

$$\mathcal{O}(\Phi_a, n_{a_l}^k). \tag{6.5}$$

Different sets of numbers $n_{a_l}^k$ may correspond to linearly-dependent operators, but it is obvious they give an over-complete set of gauge-invariant operators with given n_a .

It is still formidable to obtain the linearly independent basis of the operators from the set (6.5). Let us now introduce another set of operators for the given number m_i of epsilon symbols. They are parametrized by specifying for each arrow $a = 1, \dots, u$ a complex matrix $\lambda_{a_l}^k$ with indices $k = 1, \dots, m_{h(a)}$ and $l = 1, \dots, m_{t(a)}$. Then we form a matrix $M(\Phi, \lambda)$ with blocks $M_{(i,j)}$, $i = 1, \dots, s$ and $j = -1, \dots, -t$, which is a $m_i d_i \times m_{-j} d_{-j}$ matrix

$$M_{(i,j)l\beta}^{k\alpha} = \sum_{a \text{ with } t(a)=i, h(a)=j} \lambda_{a_l}^k \Phi_{a\beta}^\alpha \tag{6.6}$$

where $k = 1, \dots, m_j$, $l = 1, \dots, m_i$, $\alpha = 1, \dots, d_j$ and $\beta = 1, \dots, d_i$. These blocks form a w -by- w matrix $M(\Phi, \lambda)$ thanks to the relation (6.3). Thus we can take its determinant

$$D(\Phi, \lambda) \equiv \det M(\Phi, \lambda) \tag{6.7}$$

to get a gauge-invariant operator. We call them the generalized determinants.

To the authors' knowledge, operators of this type were first used in string theory literature by [10] in the study of baryonic operators for the quiver gauge theory dual to the complex cones over del Pezzos, and they seem to have been known to mathematicians for decades. A crucial observation by [28] made in this century is that $D(\Phi, \lambda)$ also forms an over-complete basis of gauge invariant operators. The only thing to be shown is that the operator (6.5) can be obtained as the linear combination of operators $D(\Phi, \lambda)$. It can be achieved by averaging $D(\Phi, \lambda)$ over λ :

$$\mathcal{O}(\Phi, n_{a_l}^k) \propto \left(\prod_{a,k,l} \oint \frac{d\lambda_{a_l}^k}{(\lambda_{a_l}^k)^{1+n_{a_l}^k}} \right) D(\Phi, \lambda) \tag{6.8}$$

where $\oint d\lambda$ is a contour integral along the unit circle $|\lambda| = 1$. Indeed, the averaging above picks the term proportional to $\prod_{a,k,l} (\lambda_{a_l}^k)^{n_{a_l}^k}$ in $D(\Phi, \lambda)$, which is seen to be $\mathcal{O}(\Phi, n_{a_l}^k)$ by some mental gymnastics.

One immediate application is to the baryons of the conifold gauge theory, recall figure 1. The preceding theorem says that a baryon constructed from $A_{1,2}$ using one epsilon symbol for each gauge group is given by

$$D(A, \lambda) = \det(\lambda_i A^i), \tag{6.9}$$

as it should be. Thus the analysis presented here can be thought of as a generalization of this well-known fact to general bipartite quiver gauge theories.

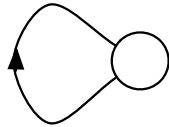

Figure 16: A quiver with one node.

6.2 Relation to quiver representations

The blocks of $M(\Phi, \lambda)$ in (6.6) is defined symmetrically with the exchange of Φ and λ . Thus, we can define the action of $g_i \in GL(m_i)$ on $\lambda_{a_l}^k$, which we schematically denote as $\lambda \rightarrow g\lambda g^{-1}$. The generalized determinant then transforms as

$$D(\Phi, g\lambda g^{-1}) = \left(\prod_{i>0} (\det g_i)^{d_i} \prod_{j<0} (\det g_j)^{-d_j} \right) D(\Phi, \lambda), \quad (6.10)$$

i.e. $D(\Phi, \lambda)$ and $D(\Phi, g\lambda g^{-1})$ determine the same operator. The important point for us is that the equivalence classes of matrices λ under the action of $GL(m_i)$ is a well-studied and beautiful branch of mathematics called the theory of representations of quivers.

Let us introduce some terminologies. (We drop the bipartite assumption for the time being.) A quiver Q is now a set of nodes $i = 1, \dots, s$ and arrows $a = 1, \dots, u$, which connect the node $t(a)$ to the node $h(a)$. A representation λ of Q is the assignment of vector spaces Λ_i to the nodes, and linear maps $\lambda_a : \Lambda_{t(a)} \rightarrow \Lambda_{h(a)}$ to the arrows. The set of numbers $\dim \lambda = (\dim \Lambda_i)_{i=1, \dots, s}$ is called the dimension vector of λ . Two representations λ, λ' is called isomorphic if $\dim \lambda = \dim \lambda'$ and moreover there is the choice of invertible matrices $g_i \in GL(\dim \Lambda_i)$ acting on Λ_i such that $\lambda'_a = g_{h(a)} \lambda_a g_{t(a)}^{-1}$ for all arrows a . The representation theory of quivers has been utilized in string theory, see e.g. [29–31]. Previous usage of quiver representations viewed Φ as the representation, whereas we mainly study the ‘dual’ quiver representation defined by λ in the expression above.

What we showed above can be rephrased as the fact that $D(\Phi, \lambda)$ and $D(\Phi, \lambda')$ define the same operator if λ and λ' are isomorphic, and that the dimension vector of $D(\Phi, \lambda)$ as defined in the previous section, i.e. the vector (m_i) where m_i is the number of epsilon symbols used for the i -th gauge group, is the dimension vector $\dim \lambda$, which explains our terminology.

Another concept is the direct sum $\lambda \oplus \lambda'$ of two representations: it is defined as the assignment of $\Lambda_i \oplus \Lambda'_i$ to the nodes and of $\lambda_a \oplus \lambda'_a$ to the arrows. A representation which can be written as a direct sum is called decomposable, and if not, indecomposable. An indecomposable representation is called stably indecomposable if no infinitesimal deformation makes the representation decomposable.

For an example, consider a quiver with one node and a loop attached to it, see figure 16. A representation of this quiver with the dimension vector (N) is just a $N \times N$ matrix, and the classification of the representations is just that of square matrices up to conjugation. It is easy to see that an indecomposable representation is a Jordan block, but a Jordan block

with more than one row becomes diagonalizable i.e. decomposable by a small perturbation. Therefore stably indecomposable representations are 1-by-1 matrices.

The usefulness of the concept of indecomposability lies in the fact that the matrix $M(\Phi, \lambda \oplus \lambda')$ is just the block diagonal sum of the matrices $M(\Phi, \lambda)$ and $M(\Phi, \lambda')$. As their determinants, $D(\Phi, \lambda)$ then satisfies the relation

$$D(\Phi, \lambda \oplus \lambda') = D(\Phi, \lambda)D(\Phi, \lambda'). \quad (6.11)$$

Thus, the generalized determinant for a decomposable λ decomposes as the product of gauge-invariant operators. One word of caution is necessary, because $D(\Phi, \lambda)$ can be decomposable even when λ is indecomposable. It often vanishes completely, e.g. for a basic indecomposable representation e_i of the quiver Q which assigns $\Lambda_i = \mathbb{C}$ and Λ_j zero-dimensional for $i \neq j$, the maps λ_a are automatically zero so that $D(\Phi, \lambda)$ is also zero. A more subtle example is when λ is indecomposable but not stably indecomposable. Take a sequence λ_i which converges to λ . By assumption $\lambda_i = g_i(\lambda'_i \oplus \lambda''_i)g_i^{-1}$ and

$$D(\Phi, \lambda_i) = D(\Phi, \lambda'_i)D(\Phi, \lambda''_i). \quad (6.12)$$

Let the limits of λ'_i and λ''_i be respectively λ' and λ'' ; λ is not isomorphic to $\lambda' \oplus \lambda''$ because the limit of g_i does not exist. Still we can take the limit of the relation (6.12) and we have

$$D(\Phi, \lambda) = D(\Phi, \lambda')D(\Phi, \lambda''), \quad (6.13)$$

i.e. $D(\Phi, \lambda)$ decomposes if λ is not stably indecomposable. Even $D(\Phi, \lambda)$ for a stably indecomposable λ sometimes decomposes as we will see, but the preceding arguments tell us that we only need to consider stably indecomposable representations to find the generators of the baryonic operators.

6.3 Theorems of Gabriel and Kac

The discussion above is extremely useful because much is known about the representations of the quivers, in particular for which the underlying diagram is one of extended or non-extended Dynkin diagram.

Now let us naively count the number of the parameters of the gauge equivalence class of a representation λ with the dimension vector $\alpha = \dim \lambda$. It has $\sum_a \alpha_{t(a)}\alpha_{h(a)}$ components, and $G = \prod_i GL(\alpha_i)$ which has $\sum_i \alpha_i^2$ parameters acts on it. The diagonal $GL(1)$ of G does not act on the matrices, so the naive number μ_α of the parameters is

$$\mu_\alpha = \sum_a \alpha_{t(a)}\alpha_{h(a)} - \sum_i \alpha_i^2 + 1 = 1 - \langle \alpha, \alpha \rangle / 2, \quad (6.14)$$

where the pairing $\langle \alpha, \beta \rangle$ is by the Cartan matrix of the graph,

$$\langle \alpha, \beta \rangle = 2 \sum_i \alpha_i \beta_i - \sum_a \alpha_{t(a)} \beta_{h(a)} - \sum_a \alpha_{h(a)} \beta_{t(a)}. \quad (6.15)$$

Appearance of the Cartan matrix in the counting of the parameters makes it very natural to identify the dimension vector α as an element $\sum \alpha_i e_i$ of the root lattice associated to the quiver, where e_i is the simple root corresponding to the i -th node.

Recall that the pairing $\langle \alpha, \beta \rangle$ is positive definite if and only if the quiver is one of the non-extended Dynkin diagram, and is positive semi-definite if and only if it is one of the extended Dynkin diagram. A vector α is called real if $\langle \alpha, \alpha \rangle > 0$ and imaginary if $\langle \alpha, \alpha \rangle \leq 0$. Then the relation (6.14) tells us that, naively speaking, we can expect a discrete number of indecomposable representations if α is a real root, i.e. $\langle \alpha, \alpha \rangle = 2$, and a μ_α -parameter family if α is imaginary.

The statement is made mathematically precise by Gabriel, who introduced the terminology “quiver” in the first place [32]:

- The number of indecomposable representations of a quiver Q is finite if and only if the underlying diagram of Q is a non-extended Dynkin diagram. Thus, such quivers are classified by A , D and E .
- When Q is Dynkin, a representation λ is indecomposable if and only if $\dim \lambda$ is one of the positive root.
- There is one and only one indecomposable representation for each positive root.

The proof utilize the so-called reflection functor which implements the Weyl reflection by the simple roots at the level of the representation of the quiver. With this tool, the proof goes almost the same as the classification of the simply-laced root systems. The reflection functor also acts on the baryonic operators through the generalized determinants $D(\Phi, \lambda)$, and it is the mathematical realization of the Seiberg duality discussed in section 5.3.

After Gabriel’s work, many people studied the extension to more general quivers, and one culmination is the result by Kac [27]:

- A representation λ is indecomposable if and only if $\dim \lambda$ is one of the positive root of the associated Kac-Moody algebra.
- There is one and only one indecomposable representation for each positive real root.
- For each positive imaginary root α , there is a μ_α -parameter family of indecomposable representations λ with $\alpha = \dim \lambda$.

If the quiver is one of the extended Dynkin diagram, the associated Kac-Moody algebra is the untwisted current algebra for the corresponding simply-laced group, and the structure of the roots are well-known, which can be readily utilized to the analysis of the \mathcal{A} -type baryons of our theory. For a readable account of the theorem, see [33]; indecomposable representations of extended Dynkin quivers are explicitly listed in [34], although the direction of the arrows are not the same as ours.

The theorems above classify indecomposable representations, but as argued in the last subsection, stably indecomposable representations are more relevant for our purposes. Fortunately they were also classified for the extended Dynkin quivers [27]. To state the theorem, let us introduce the Ringel pairing $R(\alpha, \beta)$ which is not necessarily symmetric and depends on the orientation of the arrows:

$$R(\alpha, \beta) = \sum_i \alpha_i \beta_i - \sum_a \alpha_{t(a)} \beta_{h(a)}. \tag{6.16}$$

It is related to the Cartan pairing via $\langle \alpha, \beta \rangle = R(\alpha, \beta) + R(\beta, \alpha)$. Next, let us recall the set of the positive roots of untwisted simply-laced affine Lie algebras $\widehat{\mathfrak{g}}$, which can be described as follows [35]: let us relabel the nodes so that 0-th node corresponds to the extending node of the extended Dynkin diagram. We denote the simple roots as e_i , $i = 0, 1, \dots, r$, and identify the subspace generated by e_1, \dots, e_r with the root lattice of the corresponding finite dimensional Lie algebra \mathfrak{g} . Then, the set of positive imaginary roots are $\{k\delta\}$ for k a positive integer, with

$$\delta = \sum_{i=0}^r d_i e_i \tag{6.17}$$

where d_i is the i -th Coxeter label, i.e. the dimension of the indecomposable representation of the corresponding discrete subgroup of $SU(2)$. The set $\widehat{\Delta}_+$ of positive real roots are given by

$$\widehat{\Delta}_+ = \Delta_+ \cup \{k\delta \pm r \mid r \in \Delta_+, k \in \mathbb{Z}_{>0}\}, \tag{6.18}$$

where Δ_+ is the set of positive roots of \mathfrak{g} . Now the theorem states that the dimension vector of a stably indecomposable representation is in either of the two sets

$$\widehat{\Delta}_{+,0} = \{\delta\} \cup \{\alpha, \delta - \alpha \mid \alpha \in \Delta_+ \text{ and } R(\delta, \alpha) = 0\}, \tag{6.19}$$

$$\widehat{\Delta}_{+,1} = \{\alpha \in \widehat{\Delta}_+ \mid R(\delta, \alpha) \neq 0\}. \tag{6.20}$$

6.4 Application to the study of \mathcal{A} -type baryons

Let us apply the mathematical theory reviewed in the previous sections to the classification of the baryons of our theory. The inspection of the quiver diagram reveals that the \mathcal{A} -type bifundamental fields form two disjoint sets of extended Dynkin diagrams, and thus any gauge-invariant operator is constructed by fields coming from only one of the two Dynkin diagrams. In the following we only consider one set of bifundamentals forming a Dynkin diagram.

Its nodes are colored in white and black, and all of the arrows are from white to black, and therefore from the argument in section 6.1 the only gauge invariant operators are the generalized determinants $D(\Phi, \lambda)$. As explained in section 6.2, they decompose as the product of two gauge-invariant operators if λ is not stably indecomposable. We abuse the notation and often identifies the dimension vector $\dim \lambda$ and the indecomposable representation λ itself if $\dim \lambda$ is a positive real root, since no confusion should arise.

As cautioned in section 6.2, it is not that all of the stably indecomposable representations of the quiver correspond to an indecomposable baryonic operators. But the set above gives the only possibility for such operators. The set can further be constrained, because $\dim \lambda = (\lambda_i)$, which is the number of the epsilon symbols for $SU(d_i N)$ one use to construct the operator, needs to satisfy the relations (6.2) and (6.3) for some set of non-negative integers n_a assigned to the bifundamental fields. One immediate consequence is that

$$\sum_{i \text{ white}} d_i \lambda_i = \sum_{i \text{ black}} d_i \lambda_i, \tag{6.21}$$

which is equivalent to the condition

$$R(\delta, \dim \lambda) = 0 \tag{6.22}$$

using the relation (3.4). Thus we only need to study the set $\widehat{\Delta}_{+,0}$ (6.19), and given the condition above, the weight of the operator $D(\Phi, \lambda)$ is

$$w(D(\Phi, \lambda)) = \frac{1}{2} \sum_i d_i \lambda_i. \tag{6.23}$$

Bayons of weight $|\Gamma|/2$. Let us first study the baryons with $\dim \lambda = \delta$. The weight of such operators is $|\Gamma|/2$ from (6.23). There is a one-parameter family of stably indecomposable representation λ with $\dim \lambda = \delta$, and it is known that the moduli space of such λ is \mathbb{CP}^1/Γ with the orbifold points removed⁵ [27], and it nicely matches with the moduli of the \mathcal{A} -type brane we found in section 4.2.1. We will return to the problem of counting the number of baryons of weight $|\Gamma|/2$ in section 7.

Baryons with weight less than $|\Gamma|/2$. The positive real roots in the set $\widehat{\Delta}_{+,0}$ give operators with weight less than $|\Gamma|/2$. There is at most only one baryonic operator for each of such dimension vectors. It is from the fact that the integrand in the formula (6.8) gives the same baryonic operator for almost all λ because there is only one stably indecomposable representation for each dimension vector. Still, $D(\Phi, \lambda)$ might be decomposable to the products of two baryons of lower weight. For example, if a real root w in $\widehat{\Delta}_{+,0}$ is the sum of two real root $v_{1,2} \in \widehat{\Delta}_{+,0}$ and if $D(\Phi, v_1)$ and $D(\Phi, v_2)$ is non-zero, then

$$D(\Phi, w) \propto D(\Phi, v_1)D(\Phi, v_2). \tag{6.24}$$

The reason is that any baryonic operator with dimension vector w is of the form $D(\Phi, w)$ as argued above, and the non-zero operator $D(\Phi, v_1)D(\Phi, v_2)$ has the dimension vector $w = v_1 + v_2$. Therefore, to make a baryonic operator which is not a product of gauge-invariant operators, we need to take a positive real root vector in $\widehat{\Delta}_{+,0}$ which cannot be written as the sum of vectors in $\widehat{\Delta}_{+,0}$. We call such a vector indecomposable.

Let us classify \mathcal{A} -type baryons of weight less than $|\Gamma|/2$ using the strategy outlined above. We analyze cyclic groups, dihedral groups and the polyhedral groups in turn.

Cyclic groups, A_{2n-1} . It is easy to check that only indecomposable vector in $\widehat{\Delta}_{+,0}$ is of the form $e_i + e_{i+1}$, $i = 0, \dots, n-1$ where e_n is identified with e_0 . Then the corresponding baryonic operator is just the dibaryons $\det A_{i \rightarrow i+1}$. The result agrees with the previous direct analysis in section 5.4.

Binary dihedral groups, D_{n+2} . It is straightforward to list all of elements of $\widehat{\Delta}_{+,0}$, of which the indecomposable vectors are n of weight two

$$\begin{aligned} & \begin{matrix} 1 & 0 & 0 & 0 & \dots & 0 & 0 \\ 1 & 1 & 0 & \dots & 0 & 0 & 0 \end{matrix} ', \quad \begin{matrix} 0 & 1 & 1 & 0 & \dots & 0 & 0 & 0 \end{matrix} \quad \dots ', \quad \begin{matrix} 0 & 0 & \dots & 0 & 1 & 1 & 0 & \dots & 0 & 0 \end{matrix} ', \\ & \dots ', \quad \begin{matrix} 0 & 0 & 0 & \dots & 0 & 1 & 1 & 0 \end{matrix} ', \quad \begin{matrix} 0 & 0 & 0 & \dots & 0 & 1 & 1 \end{matrix} ', \end{aligned} \tag{6.25}$$

⁵Strictly speaking, it is imprecise to refer the moduli space as \mathbb{CP}^1/Γ with orbifold points removed, because the classification of the indecomposable representation of the quiver is done in the sense of algebraic geometry, and \mathbb{CP}^1/Γ with orbifold points removed is isomorphic to \mathbb{CP}^1 with three points removed.

and four of weight n :

$$\begin{array}{ccc} 0 & 0 & 1 & 1 \\ 1 & 1 & 1 \dots 1 & 1 & 1 \end{array} , \quad \begin{array}{ccc} 0 & 1 & 1 & 1 \dots 1 & 1 & 0 \end{array} , \quad (6.26)$$

$$\begin{array}{ccc} 0 & 1 & 1 & 1 \dots 1 & 1 & 0 \\ 1 & 1 & 1 \dots 1 & 1 & 1 & 0 \end{array} , \quad \begin{array}{ccc} 0 & 1 & 1 & 1 \dots 1 & 1 & 1 \end{array} . \quad (6.27)$$

The list above matches the expectation from the analysis of the geometry. Indeed, since the corresponding Platonic triple is now $p = n$, $q = 2$ and $r = 2$, we expected n operators $\mathcal{P}_1, \dots, \mathcal{P}_n$ of weight 2 and four operators $\mathcal{Q}_{1,2}$ and $\mathcal{R}_{1,2}$ of weight n . Furthermore, the dimension vector of $\mathcal{P}_1 \dots \mathcal{P}_n$, $\mathcal{Q}_1 \mathcal{Q}_2$ and $\mathcal{R}_1 \mathcal{R}_2$ are all equal to δ . This corresponds to the decomposition (4.9) of the dibaryon at the orbifold point of \mathbb{CP}^1/Γ .

Binary tetrahedral group, E_6 . The vectors in $\widehat{\Delta}_{+,0}$ are six of weight four

$$v_1 = \begin{array}{ccc} 1 & 0 & 0 \\ 1 & 0 & 1 \\ 0 & 1 & 1 & 0 & 0 \end{array} , \quad v_2 = \begin{array}{ccc} 0 & 0 & 0 \\ 1 & 1 & 1 & 1 & 0 \end{array} , \quad v_3 = \begin{array}{ccc} 0 & 1 & 0 \\ 0 & 0 & 1 & 1 & 1 \end{array} , \quad (6.28)$$

$$v_4 = \begin{array}{ccc} 0 & 1 & 0 \\ 0 & 0 & 1 \\ 0 & 1 & 1 & 1 & 1 \end{array} , \quad v_5 = \begin{array}{ccc} 1 & 0 & 0 \\ 1 & 0 & 0 & 1 & 1 & 0 \end{array} , \quad v_6 = \begin{array}{ccc} 0 & 1 & 0 \\ 1 & 1 & 1 & 0 & 0 \end{array} ; \quad (6.29)$$

two of weight six,

$$z_1 = \begin{array}{ccc} 0 & 1 & 0 \\ 1 & 0 & 1 \\ 0 & 1 & 2 & 1 & 0 \end{array} , \quad z_2 = \begin{array}{ccc} 1 & 0 & 0 \\ 1 & 1 & 1 & 1 & 1 \end{array} ; \quad (6.30)$$

and six of weight eight

$$w_1 = \begin{array}{ccc} 0 & 1 & 1 \\ 1 & 1 & 2 & 2 & 1 \\ 1 & 1 & 2 & 2 & 1 \end{array} , \quad w_2 = \begin{array}{ccc} 1 & 2 & 0 \\ 0 & 1 & 2 & 1 & 1 \\ 1 & 2 & 2 & 1 & 1 \end{array} , \quad w_3 = \begin{array}{ccc} 1 & 1 & 0 \\ 1 & 2 & 2 & 1 & 0 \\ 0 & 1 & 2 & 2 & 1 \end{array} , \quad (6.31)$$

$$w_4 = \begin{array}{ccc} 1 & 0 & 1 \\ 2 & 1 & 1 \\ 1 & 1 & 2 & 1 & 0 \end{array} , \quad w_5 = \begin{array}{ccc} 0 & 1 & 0 \\ 1 & 2 & 2 & 1 & 1 \\ 1 & 2 & 2 & 1 & 1 \end{array} , \quad w_6 = \begin{array}{ccc} 1 & 1 & 0 \\ 0 & 1 & 2 & 2 & 1 \\ 0 & 1 & 2 & 2 & 1 \end{array} . \quad (6.32)$$

It is easy to check any of the weight-eight vectors is the sum of two weight-four vector, e.g. $w_1 = v_2 + v_3$. Therefore, as argued previously, $D(\Phi, w_1) \propto D(\Phi, v_2)D(\Phi, v_3)$. Thus, all the baryonic operators with weight less than $|\Gamma|/2 = 12$ is generated by six operators of weight four, and two of weight six. We have $v_1 + v_2 + v_3 = v_4 + v_5 + v_6 = z_1 + z_2 = \delta$. Hence it seems reasonable to identify the operator with dimension vector $v_{1,2,3}$ as \mathcal{P}_i , $v_{4,5,6}$ as \mathcal{Q}_i and $z_{1,2}$ as \mathcal{R}_i .

Binary octahedral group, E_7 . $\widehat{\Delta}_{+,0}$ consists of four vectors of weight 6

$$v_1 = \begin{array}{ccc} 0 & 0 & 0 \\ 0 & 1 & 1 & 1 & 1 & 0 & 0 \end{array} , \quad v_2 = \begin{array}{ccc} 0 & 0 & 0 \\ 0 & 0 & 1 & 1 & 1 & 1 & 0 \end{array} , \\ v_3 = \begin{array}{ccc} 1 & 1 & 1 \\ 0 & 0 & 0 & 1 & 1 & 1 & 1 \end{array} , \quad v_4 = \begin{array}{ccc} 1 & 1 & 1 \\ 1 & 1 & 1 & 1 & 0 & 0 & 0 \end{array} ; \quad (6.33)$$

three vectors of weight 8

$$w_1 = \begin{array}{cccccccc} & & & 1 & & & & \\ & & & 0 & 0 & 1 & 2 & 1 & 0 & 0 \end{array}, \quad w_2 = \begin{array}{cccccccc} & & & & & & 1 & & & \\ & & & 0 & 1 & 1 & 1 & 1 & 1 & 0 \end{array}, \quad w_3 = \begin{array}{cccccccc} & & & & & & & & 0 & \\ & & & 1 & 1 & 1 & 1 & 1 & 1 & 1 \end{array}; \quad (6.34)$$

six of weight 12, three of weight 16, and four of weight 18. Of the six weight-12 vectors, four can be written as the sum of two weight-four vectors. The indecomposable ones are then two remaining ones:

$$z_1 = \begin{array}{cccccccc} & & & & & & 1 & & & \\ & & & 0 & 1 & 2 & 2 & 1 & 1 & 1 \end{array}, \quad z_2 = \begin{array}{cccccccc} & & & & & & & & 1 & \\ & & & 1 & 1 & 1 & 2 & 2 & 1 & 0 \end{array}. \quad (6.35)$$

All of weight-16 and weight-18 vectors are decomposable. We find $v_1 + v_2 + v_3 + v_4 = w_1 + w_2 + w_3 = z_1 + z_2 = \delta$.

Binary icosahedral group, E_8 . The vectors in $\hat{\Delta}_{+,0}$ are five of weight 12

$$v_1 = \begin{array}{cccccccc} & & & & & & 1 & & & \\ & & & 1 & 1 & 1 & 1 & 1 & 1 & 0 \end{array}, \quad v_2 = \begin{array}{cccccccc} & & & & & & & & 0 & \\ & & & 0 & 1 & 1 & 1 & 1 & 1 & 0 \end{array}, \quad v_3 = \begin{array}{cccccccc} & & & & & & & & & 0 \\ & & & 0 & 0 & 1 & 1 & 1 & 1 & 1 \end{array},$$

$$v_4 = \begin{array}{cccccccc} & & & & & & & & 1 & \\ & & & 0 & 0 & 0 & 1 & 1 & 1 & 1 \end{array}, \quad v_5 = \begin{array}{cccccccc} & & & & & & & & & 1 \\ & & & 0 & 0 & 0 & 0 & 1 & 2 & 1 \end{array}; \quad (6.36)$$

three of weight 20,

$$w_1 = \begin{array}{cccccccc} & & & & & & & & 1 & \\ & & & 0 & 0 & 1 & 2 & 2 & 2 & 1 \end{array}, \quad w_2 = \begin{array}{cccccccc} & & & & & & & & & 1 \\ & & & 0 & 1 & 1 & 1 & 2 & 2 & 1 \end{array}, \quad w_3 = \begin{array}{cccccccc} & & & & & & & & & 1 \\ & & & 1 & 1 & 1 & 1 & 1 & 2 & 2 \end{array}; \quad (6.37)$$

two of weight 30,

$$z_1 = \begin{array}{cccccccc} & & & & & & & & & 2 \\ & & & 0 & 1 & 2 & 2 & 2 & 3 & 2 \end{array}, \quad z_2 = \begin{array}{cccccccc} & & & & & & & & & 1 \\ & & & 1 & 1 & 1 & 2 & 3 & 3 & 2 \end{array}; \quad (6.38)$$

and five of weight 24, five of weight 36, three of weight 40 and five of weight 48. The vectors with weight 24, 36, 40 or 48 are all decomposable. We also find $\sum v_i = \sum w_i = \sum z_i = \delta$.

Summary. For all the cases, we found k operators of weight $|\Gamma|/(2k)$ for each of the orbifold points of S^2/Γ , as predicted by the geometry of the orbifold of $T^{1,1}$. We also found that together with operators of dimension vector δ , they generate the whole \mathcal{A} -type baryons, which matches the prediction of the AdS/CFT correspondence from the analysis of the bulk side. We have also constructed operators of dimension $|\Gamma|/(2k)$ in section 4.2.2. We check that those operators have the dimension vectors listed above in appendix B.

7. Dimension of the \mathcal{A} -type baryonic branch

As a final exercise, let us count the dimension of the moduli space of alternating Dynkin quivers and compare with the number of the generator of the \mathcal{A} -type baryonic operators. We will find that for $N > 1$ there is no non-linear relation among the generators of the baryonic operators. In a more mathematical parlance, it means that the chiral ring of \mathcal{A} -type baryons of our theory is just a polynomial ring.

The moduli space we study in this section is not the full moduli space of the gauge theory, but presumably it will describe the branch where all of the vacuum expectation values for \mathcal{B} -type baryonic fields vanish. Then, the remaining fields are just \mathcal{A} -type bifundamentals, and therefore the branch will be just two copies of the moduli space we study.

7.1 Dimension of the moduli space

The moduli space in question is that of the \mathcal{A} -type fields which form one alternating Dynkin diagram, i.e. we have gauge groups $SU(d_s N)$ at the nodes and the bifundamentals are specified by the arrows. We denote by n_Γ the number of the nodes of the extended Dynkin diagram of type Γ . As always, we complexify the gauge groups to $SL(d_s N)$ instead of imposing the D-term conditions. If we further enlarge the gauge groups to $GL(d_s N)$, the study of the moduli space is exactly equivalent to the study of the indecomposable representation of the same quiver with dimension vector $N\delta$.

As we quoted in section 6.3, generic points in the moduli are the direct sum of N indecomposable representations of dimension vector δ , each of which has one parameter. Thus it has N complex parameters. But it is for the gauge group $U(d_s N)$, and we need the result for the gauge group $SU(d_s N)$. Of the $U(1)^{n_\Gamma}$ in the difference, only $n_\Gamma - 1$ act non-trivially on the bifundamentals, because the simultaneous $U(1)$ rotation for each of the $U(d_s N)$ gauge groups does not change the bifundamental fields at all. Thus, there are $n_\Gamma - 1$ extra degrees of freedom in the moduli space for the gauge group $SU(d_s N)$ in addition to the moduli space for the gauge group $U(d_s N)$. Therefore the number of the parameters is

$$N + n_\Gamma - 1. \tag{7.1}$$

7.2 Number of generators

We counted the number of generators with weight less than $|\Gamma|/2$ in section 6.4. We already saw for \mathbb{Z}_{2n} we have $2n$ operators of weight 2, and for non-Abelian Γ with the associated Platonic triple (p, q, r) we had p operators $\mathcal{P}_{1,\dots,p}$, q operators $\mathcal{Q}_{1,\dots,q}$ and r operators $\mathcal{R}_{1,\dots,r}$.

Hence we only need to find the number of the operators with weight $|\Gamma|/2$. As we discussed, they are spanned by the generalized determinants $D(A, \lambda)$ with the number of the epsilon symbols dictated by the dimension vector δ . From the theorem of Kac, we know that λ has one complex parameter up to gauge equivalence. We also discussed the operator $\mathcal{A}_{+\rightarrow-}$ and $\mathcal{A}_{-\rightarrow+}$ of weight $|\Gamma|/2$ in section 4.2.2, where it appeared as the decomposition of the dibaryon $\det(\lambda_i A^i)$ in the unorbifolded theory. We saw that λ_i and λ'_i related by the action of Γ give the same baryonic operator thanks to the condition (3.11),

$$A^i = \rho_2(h)_j^i \rho_r(h) A^j \rho_r(h)^{-1}, \tag{7.2}$$

and that the moduli space of λ_i can be identified with S^2/Γ . Thus what needs to be studied is the number of linearly-independent operators obtained from $\mathcal{A}_{+\rightarrow-}(\lambda)$.

Let us recall $\mathcal{A}_{+\rightarrow-}(\lambda_i)$ is the determinant of a block $\lambda_i A_{+\rightarrow-}^i$ of the matrix $\lambda_i A^i$ which maps V_+ to V_- , where V_\pm is the eigenspace of $-1 \in SU(2)$ with eigenvalue ± 1 of the regular

representation ρ_r . Let us say $\rho_r = \rho_+ \oplus \rho_-$ under this decomposition. Then the orbifold projection is now

$$A_{+ \rightarrow -}^i = \rho_2(h)_j^i \rho_-(h) A_{+ \rightarrow -}^j \rho_+(h)^{-1}. \quad (7.3)$$

Therefore the determinant $\mathcal{A}_{+ \rightarrow -}(\lambda_i)$ satisfies the relation

$$\mathcal{A}_{+ \rightarrow -}(\lambda) = (\det \rho_+(h) \det \rho_-(h)^{-1})^N \mathcal{A}_{+ \rightarrow -}(\rho_2(h)\lambda) \quad (7.4)$$

$$= (\det \rho_r(h))^N \mathcal{A}_{+ \rightarrow -}(\rho_2(h)\lambda), \quad (7.5)$$

where we used the facts that there are N copies of the regular representation, and $\det \rho_{\pm} = \pm 1$.

$\mathcal{A}_{+ \rightarrow -}$ is a polynomial of $\lambda_{1,2}$ of pure degree $N|\Gamma|/2$. Then, the relation above (7.5) means that Γ acts on the polynomial as the representation

$$(\det \rho_r)^N \otimes \text{Sym}^{N|\Gamma|/2}(\rho_2). \quad (7.6)$$

If a polynomial is not invariant under Γ , the operator vanishes by averaging over Γ . Thus the number of linearly independent operators is at most the number of invariant vectors in the representation (7.6).

The one-dimensional representation $\det \rho_r$ is found to be non-trivial only for D_{odd} , where it is equal to the representation $1'$ in the table (A.3) in the appendix A. Then a straightforward application of the orthogonality of the characters or Molien's formula shows there are $N + 1$ invariant vectors, irrespective of Γ . This number $N + 1$ includes the decomposable baryons formed by the fractional baryons.

Abelian Γ . It is the case when $\Gamma = \mathbb{Z}_{2n}$. It is easy to see that there are two ways of constructing baryons of dimension vector δ from the baryons of weight 2. Thus we expect $N - 1$ independent operators with weight $|\Gamma|/2 = n$, which precisely agrees with what we found in section 5.4.1. In total, we have $N + 2n - 1$ operators, which is equal to (7.1).

Non-Abelian Γ . As we saw, $\prod \mathcal{P}_i$, $\prod \mathcal{Q}_i$ and $\prod \mathcal{R}_i$ give three baryonic operators with dimension vector δ . Since we have $N + 1$ independent operators with this dimension vector, we believe for $N > 1$ these three products are linearly-independent, and the rest of $N + 1$ operators gives $N - 2$ linearly independent baryons. In total, we have

$$N - 2 + p + q + r \quad (7.7)$$

generators of baryons. Now, an interesting fact is that we have the relation

$$p + q + r = n_{\Gamma} + 1 \quad (7.8)$$

for Dynkin diagrams of D and E type. Thus (7.1) and (7.7) give the same number.

Now we have shown that the number of generators of the \mathcal{A} -type baryonic operators is equal to the dimension of the moduli space of the \mathcal{A} -type baryons. Therefore, there can be no non-linear relation among the generators obtained thus far, and we have a surprisingly simple result that the chiral ring of \mathcal{A} -type baryons is just a polynomial ring for $N > 1$. Indeed, it agrees with the result of [17] which was obtained in a different method. The case $N = 1$ is further discussed in appendix D.

8. Summary and discussion

Let us summarize what we have obtained so far. We considered the AdS/CFT duality between Type IIB string theory on $T^{1,1}/\Gamma$ and the corresponding gauge theory, especially the mapping between the wrapped D3-branes and the baryonic operator of the quiver gauge theory. We first started by constructing the gauge theory by applying the prescription of Douglas and Moore to the theory of Klebanov and Witten. The geometry of $T^{1,1}/\Gamma$ told us that the number of the baryonic operators in the gauge theory is dictated by the structure of the action of the group Γ on S^2 . We found the expected number of the baryonic operators by decomposing the dibaryons of un-orbifolded theory.

The rest of the paper was devoted to show that the baryons thus discovered exhaust the set of indecomposable baryons. It was with the help of the untangling procedure, the Seiberg duality and the theory of quiver representations that we accomplished the task. Moreover, we found that there is no non-linear relation among the generators of the baryonic operators. We believe the technique we developed and/or imported from the mathematics of quiver representation can be utilized in the study of the baryons of non-toric and/or non-conformal quiver gauge theory, where the ranks of the gauge groups are in general different from each other, as they were in our case.

An immediate generalization will be the study of the baryonic operators of the dual gauge theory of other non-Abelian orbifolds of Sasaki-Einstein spaces. One natural candidate is S^5/Γ , where Γ is a non-Abelian finite subgroup of $SU(3)$. The main difficulty is that the moduli space of the wrapped D3-branes is much more intricate in the geometry side, and that the quiver does not nicely split into alternating Dynkin diagrams in the gauge theory side.

Another candidate will be the study of the orbifold of $Y^{p,q}$. Here $Y^{p,q}$ spaces are the infinite series of explicit Sasaki-Einstein spaces in five dimensions found in [36] with the isometry $SU(2) \times U(1)^2$, and the corresponding quiver was constructed in [37]. We can take a non-Abelian subgroup Γ of $SU(2)$ isometry and consider the space $Y^{p,q}/\Gamma$, which has $U(1)^2$ as the isometry group and not more. The quiver for $Y^{p,q}/\Gamma$ can be constructed exactly as in section 3.3 and is nicely described using the alternating Dynkin quiver. The analyses of the geometry and of the gauge theory in section 4 carry through mostly unchanged also in these cases. There might still be a new phenomena in these examples.

Non-conformal deformation of our quiver gauge theory might also be interesting; the Klebanov-Strassler solution [38], and the baryonic deformation of it [39, 40] breaks the $U(1)_R$ symmetry but respects $SU(2) \times SU(2)$ symmetry. Thus the non-conformal version of our quiver should have a moduli space of stable supersymmetric vacua. It might have some interesting properties which are not directly inherited from the un-orbifolded cases. We hope to revisit these questions in a future publication.

Acknowledgments

The authors would like to thank Dario Martelli for various stimulating discussions. They

also appreciate helpful comments by Amihay Hanany, Yoshiyuki Kimura, Igor Klebanov, and Johannes Walcher. The work of FY is supported by Japan Society for the Promotion of Science Research Fellowships for Young Scientists. YT is supported by the United States DOE Grant DE-FG02-90ER40542.

A. Tables of representations of discrete subgroups of SU(2)

In this appendix we list the irreducible representations of discrete subgroups of SU(2). We list the explicit representation matrices for cyclic and binary dihedral groups, and we present only the character tables for binary tetra-, octa- and icosahedral groups.

Cyclic groups. The group is \mathbb{Z}_n generated by g , and there are n irreducible one-dimensional representations ρ_i on which g is represented by α^i . Here, α is $\exp(2\pi i/n)$.

Binary dihedral groups. It is denoted by \widehat{D}_n , and has $4n$ elements, and is generated by elements a, b and z with the relations $a^n = b^2 = (ab)^2 = z, z^2 = 1$. There are $n-1$ two-dimensional irreducible representations $\rho_{2,k}, k = 1, \dots, n-1$ where a and b are represented by

$$a = \begin{pmatrix} \alpha^k & \\ & \alpha^{-k} \end{pmatrix}, \quad b = \begin{pmatrix} & i^k \\ i^k & \end{pmatrix} \quad (\text{A.1})$$

where $\alpha = \exp(\pi i/n)$. $\rho_{2,1}$ is the fundamental two-dimensional representation ρ_2 which is defined through the embedding $\Gamma \subset \text{SU}(2)$. We can similarly define the representations $\rho_{2,0}$ and $\rho_{2,n}$, but each of them decomposes as the sum of two one-dimensional representations,

$$\rho_{2,0} = \rho_1 \oplus \rho'_1, \quad \rho_{2,n} = \rho''_1 \oplus \rho'''_1 \quad (\text{A.2})$$

where a and b are represented by the following scalar multiplication:

$$\begin{array}{c|cccc} & 1 & 1' & 1'' & 1''' \\ \hline a & 1 & 1 & -1 & -1 \\ b & 1 & -1 & i^n & -i^n \end{array} \quad (\text{A.3})$$

Binary tetrahedral group, E_6 . The group has 24 elements, and is generated by elements a, b, c and z with the relations $a^3 = b^3 = c^2 = z, c = ab, z^2 = 1$. Irreducible representations are three of dimension one which we call 1, 1', 1''; three of dimension two 2, 2', 2'' and one three-dimensional representation 3. The character table follows:

	e	z	c	a	a^2	b	b^2
1	1	1	1	1	1	1	1
1'	1	1	1	ω	ω^2	ω^2	ω
1''	1	1	1	ω^2	ω	ω	ω^2
2	2	-2	0	1	-1	1	-1
2'	2	-2	0	ω	$-\omega^2$	ω^2	$-\omega$
2''	2	-2	0	ω^2	$-\omega$	ω	$-\omega^2$
3	3	3	-1	0	0	0	0

(A.4)

where $\omega = \exp(2\pi i/3)$.

Binary octahedral group, E_7 . The group has 48 elements, and is generated by elements a, b, c and z with the relations $a^4 = b^3 = c^2 = z, c = ab, z^2 = 1$. Irreducible representations are 1, 2, 3, 4, 3', 2', 1' and 2'', where the number denotes the respective dimension and the prime distinguishes different irreducible representations of the same dimension. The character table is the following:

	e	z	c	a	a^2	a^3	b	b^2
1	1	1	1	1	1	1	1	1
1'	1	1	-1	-1	1	-1	1	1
2	2	-2	0	$\sqrt{2}$	0	$-\sqrt{2}$	1	-1
2'	2	-2	0	$-\sqrt{2}$	0	$\sqrt{2}$	1	-1
3	3	3	-1	1	-1	1	0	0
3'	3	3	1	-1	-1	-1	0	0
4	4	-4	0	0	0	0	-1	1
2''	2	2	0	0	2	0	-1	-1

(A.5)

Binary icosahedral group, E_8 . The group has 120 elements, and is generated by elements a, b, c and z with the relations $a^5 = b^3 = c^2 = z, c = ab, z^2 = 1$. Irreducible representations are 1, 2, 3, 4, 5, 6, 4', 2', and 3'', where the notation is as before. The character table is given by

	e	z	c	a	a^2	a^3	a^4	b	b^2
1	1	1	1	1	1	1	1	1	1
2	2	-2	0	φ	φ^{-1}	$-\varphi^{-1}$	$-\varphi$	1	-1
3	3	3	-1	φ	$-\varphi^{-1}$	$-\varphi^{-1}$	φ	0	0
4	4	-4	0	1	-1	1	-1	-1	1
5	5	5	1	0	0	0	0	-1	-1
6	6	-6	0	-1	1	-1	1	0	0
4'	4	4	0	-1	-1	-1	-1	1	1
2'	2	-2	0	$-\varphi^{-1}$	$-\varphi$	φ	φ^{-1}	1	-1
3''	3	3	-1	$-\varphi^{-1}$	φ	φ	$-\varphi^{-1}$	0	0

(A.6)

where φ is the golden ratio $(1 + \sqrt{5})/2$. As is well known, φ and $-\varphi^{-1}$ solve $x^2 = x + 1$.

B. Fractional dibaryons as generalized determinants

In this section we study the relation of the fractional dibaryons constructed geometrically in section 4.2.2 and the baryonic operators constructed in section 6.4.

To see this, let us calculate the dimension vector of the fractional dibaryon $\mathcal{A}_{i \rightarrow i+1}$. Recall that it is defined as the determinant of the block which maps V_i to V_{i+1} , where V_i is the eigenspace of $g \in \mathbb{Z}_{2k} \subset \Gamma$ with eigenvalue α^i acting on the N copies of the regular representation ρ_Γ of Γ . Here, α is $\exp(\pi i/k)$.

To translate the operator to the language of the gauge theory, we change the basis of ρ_Γ to the one as the direct sum of irreducible representations, see (3.6). As explained in

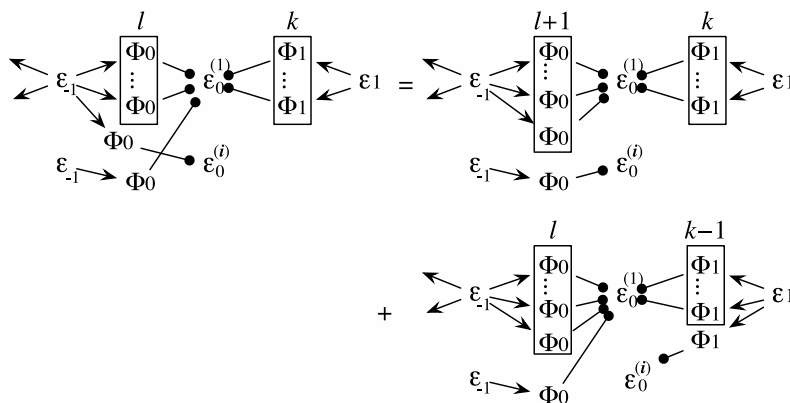

Figure 17: Application of the Plücker relation. Black blobs are the indices a_1, \dots, a_{N+1} .

As a preparation, we apply the untangling procedure repeatedly, starting from Φ_1 at $SU(N)_1$, then for Φ_2 at $SU(N)_2$, all the way to Φ_{2n-1} at $SU(N)_{2n-1}$. Then the operator is now some complicated contraction by m epsilon symbols of $SU(N)_0$ of the following operators O_k which are gauge-invariant under $SU(N)_i$ for $1 \leq i \leq 2n - 1$:

$$O_k = (\Phi_1)^k \varepsilon_1 (\Phi_2)^{N-k} \varepsilon_2 (\Phi_3)^k \cdots (\Phi_{2n-1})^k \varepsilon_{2n-1} (\Phi_0)^{N-k}. \quad (C.1)$$

For $m = 1$, the only way to make it gauge invariant is to contract k indices of $(\Phi_1)^k$ and $N - k$ indices of $(\Phi_{2n})^{N-k}$, which gives the operators O_k we found in section 5.4.1.

For $m > 1$, the operator is now of the form

$$\varepsilon^{(1)} O_{k_1} \varepsilon^{(2)} O_{k_2} \cdots \varepsilon^{(m)} O_{k_m} \quad (C.2)$$

where k_i of Φ_1 are all contracted against the epsilon symbol $\varepsilon^{(i)}$ of $SU(N)_0$. We can assume $k_1 \leq k_2 \leq \cdots \leq k_m$ without loss of generality. Now the remaining choice in the contraction is how Φ_{2n} in O_{k_i} are contracted against $\varepsilon^{(j)}$. Let ℓ_1 be the number of Φ_0 in O_{k_1} contracted against $\varepsilon^{(1)}$.

We use a double mathematical induction in k_1 and ℓ_1 to show that it can be reduced to a polynomial in $\det \Phi_i$ and O_k . First, it contains $\det \Phi_0$ as a factor if $k_1 = 0$. Second, it contains O_k as a factor if $\ell_1 = N - k_1$. Third, let us assume that any operator can be decomposed if $k_1 < k$ or $k_1 = k$, $\ell_1 > \ell$, and consider an operator with $k_1 = k$ and $\ell_1 = \ell$. Now k of Φ_1 , ℓ of Φ_0 contract against $\varepsilon^{(1)}$. Since $k + \ell < N$, we have at least one Φ_0 in O_{k_1} contracting against $\varepsilon^{(i)}$, $i > 1$. Now we apply the Plücker relation

$$\varepsilon_{[a_1 a_2 \cdots a_N \varepsilon_{a_{N+1}}] b_2 \cdots b_N} = 0 \quad (C.3)$$

to $\varepsilon^{(1)} \varepsilon^{(i)}$, with the index contracted to Φ_0 in O_{k_1} as a_{N+1} . Then the terms in the resulting expression either have $\ell_1 = \ell + 1$, $k_1 = k$ or $\ell_1 = \ell$, $k_1 = k - 1$, see figure 17. The terms with $k_1 = k - 1$ is not exactly of the form in (C.2), but they can be made so by untangling $\Phi_2, \Phi_3, \dots, \Phi_{2n}$. Then the mathematical induction implies it can be decomposed into a polynomial of $\det \Phi_i$ and O_k .

Binary dihedral groups, $\Gamma = \widehat{\mathcal{D}}_n$. Here we show that any baryonic operator of the D -type alternating Dynkin quiver can be written as the polynomial of the basic operator which we obtained in section 5.4.2. We continue to use the notation in that section. We denoted the dimension vector as $(m, m', m'', m'''; m_i)$, and we showed that the operator decomposes unless $m + m' = m'' + m''' = m_i$. Let us set $\mu = m_i$ for brevity. We show any operator with $\mu \geq 3$ is a product of operators with $\mu = 1, 2$.

We first perform the untangling procedure beginning from W and Z at $SU(2N)_{n-2}$, repeatedly to Φ_1 at $SU(2N)_1$. Then the bifundamental fields other than U and V are combined to the parts

$$\mathcal{W}^{a_1 \dots a_N} = \varepsilon^{a_1 \dots a_N c_1 \dots c_N} (\Phi_1)_{c_1 \dots c_N}^N \varepsilon_2 (\Phi_2)^N \dots (\Phi_{n-2})^N \varepsilon_{n-1} W^N \varepsilon_{N''}, \quad (\text{C.4})$$

$$\mathcal{Z}^{a_1 \dots a_N} = \varepsilon^{a_1 \dots a_N c_1 \dots c_N} (\Phi_1)_{c_1 \dots c_N}^N \varepsilon_2 (\Phi_2)^N \dots (\Phi_{n-2})^N \varepsilon_{n-1} Z^N \varepsilon_{N'''}. \quad (\text{C.5})$$

Here, $\varepsilon^{a_1 \dots a_{2N}}$ is the epsilon symbol for $SU(2N)_1$, ε_i is the one for $SU(2N)_i$, and we suppressed the indices of the gauge groups other than $SU(2N)_1$ for the sake of simplicity. As a byproduct of the untangling procedure above, we have the relations

$$\mathcal{W}^{[a_1 \dots a_N] \mathcal{W}^{b_1] \dots b_N} = \mathcal{Z}^{[a_1 \dots a_N] \mathcal{Z}^{b_1] \dots b_N} = 0. \quad (\text{C.6})$$

Then we untangle U_a and V_a connected to \mathcal{W} 's at $SU(N)$ and $SU(N)'$. It makes U, V and \mathcal{W} to combine into polynomials of \mathcal{U}, \mathcal{V} and O_k ($k = 0, \dots, N$) defined as follows:

$$\mathcal{U}_{a_1 \dots a_N} = \varepsilon_N (U^N)_{a_1 \dots a_N}, \quad (\text{C.7})$$

$$\mathcal{V}_{a_1 \dots a_N} = \varepsilon_{N'} (V^N)_{a_1 \dots a_N}, \quad (\text{C.8})$$

$$O_{k[a_1 \dots a_k][b_1 \dots b_{N-k}]} = \mathcal{U}_{a_1 \dots a_k c_1 \dots c_{N-k}} \mathcal{V}_{b_1 \dots b_{N-k} d_1 \dots d_k} \mathcal{W}^{c_1 \dots c_{N-k} d_1 \dots d_k}. \quad (\text{C.9})$$

Thus, the problem is now reduced to the study of the contraction of operators $\mathcal{U}, \mathcal{V}, O_k$ to the operators \mathcal{Z} . The important point here is that \mathcal{Z} satisfies the Plücker-like relation (C.6).

First, when a \mathcal{U} is contracted to a product of several \mathcal{Z} , repeated application of the Plücker-like relation can make all of the indices of \mathcal{U} to contract against one \mathcal{Z} . Thus it contains $\mathcal{U}\mathcal{Z}$ as a factor. One can make the same argument for \mathcal{V} .

Then the remaining case to analyze is a baryonic operator where the product of μ of O_k 's is contracted against μ of \mathcal{Z} , which we distinguish as $\mathcal{Z}_{(i)}$, ($i = 1, \dots, \mu$). Suppose there are k_i of U fields contracted against $\mathcal{Z}_{(i)}$. Application of the untangling procedure for bifundamentals in O_k 's in the order $U, V, \Phi_1, \Phi_2, \dots$, we see that such an operator can be expressed as

$$\prod_i O_{k_i} \mathcal{Z}_{(i)} \quad (\text{C.10})$$

where k_i indices of U inside O_{k_i} are all contracted against $\mathcal{Z}_{(i)}$. Let ℓ_i be the number of indices of \mathcal{V} inside O_{k_i} contracted against $\mathcal{Z}_{(i)}$. Now we can apply the same mathematical induction for l_1 and k_1 as in the case of cyclic groups treated in the previous subsection, and we find that the operator can be decomposed as a polynomial of $O_{k, a_1 \dots a_N} \mathcal{Z}^{a_1 \dots a_N}$. This is what we wanted to prove.

Binary icosahedral group, \mathcal{I} . Let us study the icosahedral case to exemplify how we can enumerate baryons of alternating Dynkin quiver of exceptional type. The quiver was already depicted in figure 8. Suppose we are given a baryonic operator. We first apply the untangling procedure to the bifundamentals repeatedly, from the endpoint of three legs of the extended quiver to the junction of them. Then the bifundamentals of each leg are organized into the following combinations:

$$\begin{aligned}
 \mathcal{U}_{3N} &= \varepsilon_{(1)} \mathcal{A}_{1 \rightarrow 2}^N \quad \varepsilon_{(2)} \mathcal{A}_{3 \rightarrow 2}^N \quad \varepsilon_{(3)} \mathcal{A}_{3 \rightarrow 4}^{2N} \quad \varepsilon_{(4)} \mathcal{A}_{5 \rightarrow 4}^{2N} \quad \varepsilon_{(5)} \mathcal{A}_{5 \rightarrow 6}^{3N}, \\
 \mathcal{U}_{2N} &= \quad \quad \quad \varepsilon_{(2)} \mathcal{A}_{3 \rightarrow 2}^{2N} \quad \varepsilon_{(3)} \mathcal{A}_{3 \rightarrow 4}^N \quad \varepsilon_{(4)} \mathcal{A}_{5 \rightarrow 4}^{3N} \quad \varepsilon_{(5)} \mathcal{A}_{5 \rightarrow 6}^{2N}, \\
 \mathcal{U}_{4N} &= \quad \quad \quad \quad \quad \quad \varepsilon_{(3)} \mathcal{A}_{3 \rightarrow 4}^{3N} \quad \varepsilon_{(4)} \mathcal{A}_{5 \rightarrow 4}^N \quad \varepsilon_{(5)} \mathcal{A}_{5 \rightarrow 6}^{4N}, \\
 \mathcal{U}_N &= \quad \quad \quad \quad \quad \quad \quad \quad \quad \varepsilon_{(4)} \mathcal{A}_{5 \rightarrow 4}^{4N} \quad \varepsilon_{(5)} \mathcal{A}_{5 \rightarrow 6}^N, \\
 \mathcal{U}_{5N} &= \quad \quad \quad \quad \quad \quad \quad \quad \quad \quad \quad \quad \varepsilon_{(5)} \mathcal{A}_{5 \rightarrow 6}^{5N}; \\
 \mathcal{V}_{2N} &= \varepsilon_{(2')} \mathcal{A}_{4' \rightarrow 2'}^{2N} \varepsilon_{(4')} \mathcal{A}_{4' \rightarrow 6}^{2N}, \\
 \mathcal{V}_{4N} &= \quad \quad \quad \varepsilon_{(4')} \mathcal{A}_{4' \rightarrow 6}^{4N}; \\
 \mathcal{W}_{3N} &= \varepsilon_{(3')} \mathcal{A}_{3' \rightarrow 6}^{3N}.
 \end{aligned} \tag{C.11}$$

Here, $\mathcal{A}_{a \rightarrow b}$ stands for the bifundamental field connecting $SU(aN)$ and $SU(bN)$ gauge groups, $\varepsilon_{(i)}$ the epsilon symbol for $SU(iN)$, and contraction of the gauge indices other than those of $SU(6N)$ should be understood. The subscripts of \mathcal{U} , \mathcal{V} and \mathcal{W} denote the number of anti-symmetric indices of $SU(6N)$. The remaining task is to combine these operators with as many epsilon symbols for $SU(6N)$ as necessary.

Now we can enumerate the baryons according to the number m_6 of the epsilon symbols used for $SU(6N)$, but it becomes more and more cumbersome as m_6 increases. Let us content ourselves by showing that the operators of lowest weight is of weight 12, and there are five of them.

For $m_6 = 1$, we find the following four operators:

operator	dim. vector	
$\varepsilon_{(6)} \mathcal{U}_{3N} \mathcal{W}_{3N}$,	1 1 1 1 1 1 0 0'	1
$\varepsilon_{(6)} \mathcal{U}_{2N} \mathcal{V}_{4N}$,	0 1 1 1 1 1 1 0'	0
$\varepsilon_{(6)} \mathcal{U}_{4N} \mathcal{V}_{2N}$,	0 0 1 1 1 1 1 1'	0
$\varepsilon_{(6)} \mathcal{U}_N \mathcal{V}_{2N} \mathcal{W}_{3N}$,	0 0 0 1 1 1 1 1'	1

(C.12)

They are all of weight $12N$. Other combinations automatically vanish. For example, $\varepsilon_{(6)} \mathcal{U}_{4N} \mathcal{U}_{2N}$ antisymmetrizes $6N$ of the bifundamental $\mathcal{A}_{5 \rightarrow 6}$, which is a $5N \times 6N$ matrix. Therefore it vanishes from the consideration of the rank. For $m_6 = 2$, the only possibility with weight not more than 12 is

$$\varepsilon_{(6)} \varepsilon_{(6)} \mathcal{U}_{5N} \mathcal{V}_{4N} \mathcal{W}_{3N}, \tag{C.13}$$

with dimension vector

$$\begin{array}{c} 1 \\ 0 \ 0 \ 0 \ 0 \ 1 \ 2 \ 1 \ 0' \end{array} \tag{C.14}$$

The fact that we have two epsilon symbols means that there are various way of contracting indices, with many possibly linearly-independent operators. However, as was discussed in section 5.3, the Seiberg duality turns it to one of the operators in (C.12), which is guaranteed to have one unique operator for one dimension vector. Thus we only have one independent operator of weight 12 with $m_6 = 2$. Finally we can check there are no operator of weight not more than $12N$ with $m_6 > 2$. This completes the enumeration of lowest-weight operators, that is, there are five operators with weight 12.

D. Non-linear relations among baryonic generators for $N = 1$

As discussed in section 7.2, we have $N + 1$ linearly independent operators with dimension vector δ , while it is easy to see that three operators $\mathcal{P}_1 \cdots \mathcal{P}_p, \mathcal{Q}_1 \cdots \mathcal{Q}_q$ and $\mathcal{R}_1 \cdots \mathcal{R}_r$ share the same dimension vector δ . Therefore, there should be one non-linear relation among the generators $\mathcal{P}_i, \mathcal{Q}_i$ and \mathcal{R}_i for $N = 1$. We report here how such a relation can be derived for $\Gamma = \widehat{D}_n$.

The gauge groups are now $SU(2)_1 \times \cdots \times SU(2)_{n-1}$, As matter superfields, we have bifundamentals Φ_i connecting $SU(2)_i$ and $SU(2)_{i+1}$, and in addition two fundamentals U, V for $SU(2)_1$ and W, Z for $SU(2)_{n-1}$. We need not distinguish fundamental and anti-fundamental representation, since any gauge group is $SU(2)$. Thus we can assume any contraction is done by ε_{ab} . A fundamental identity is the Plücker relation

$$\varepsilon_{ab}\varepsilon_{cd} = \varepsilon_{ac}\varepsilon_{bd} - \varepsilon_{ad}\varepsilon_{bc}, \tag{D.1}$$

which can be depicted as

$$\begin{array}{c}
 a \\
 | \\
 b
 \end{array}
 \begin{array}{c}
 | \\
 c \\
 | \\
 d
 \end{array}
 =
 \begin{array}{c}
 a \\
 | \\
 b
 \end{array}
 \begin{array}{c}
 - \\
 c \\
 | \\
 d
 \end{array}
 -
 \begin{array}{c}
 a \\
 | \\
 b
 \end{array}
 \begin{array}{c}
 \times \\
 c \\
 | \\
 d
 \end{array}
 \tag{D.2}$$

where a line connecting two indices stands for the epsilon symbol. Now the product of n operators of type \mathcal{P}_i is

$$\begin{array}{c}
 U \\
 | \\
 V
 \end{array}
 \begin{array}{c}
 | \\
 \Phi_1 \\
 | \\
 \Phi_1
 \end{array}
 \begin{array}{c}
 | \\
 | \\
 | \\
 \cdots \\
 | \\
 | \\
 | \\
 \Phi_{n-2} \\
 | \\
 \Phi_{n-2}
 \end{array}
 \begin{array}{c}
 | \\
 W \\
 | \\
 Z
 \end{array}
 \tag{D.3}$$

Applying (D.2), we have

$$= \frac{U}{V} \begin{array}{c} (- \\ - \\ \times) \end{array} \begin{array}{c} \Phi_1 \\ \Phi_1 \end{array} \begin{array}{c} (- \\ - \\ \times) \end{array} \cdots \begin{array}{c} (- \\ - \\ \times) \end{array} \begin{array}{c} \Phi_{n-2} \\ \Phi_{n-2} \end{array} \begin{array}{c} (- \\ - \\ \times) \end{array} \frac{W}{Z} \tag{D.4}$$

$$\propto (U\Phi_1 \cdots \Phi_{n-2}W)(V\Phi_1 \cdots \Phi_{n-2}Z) - (U\Phi_1 \cdots \Phi_{n-2}Z)(V\Phi_1 \cdots \Phi_{n-2}W) \tag{D.5}$$

$$= \mathcal{Q}_1\mathcal{Q}_2 - \mathcal{R}_1\mathcal{R}_2, \tag{D.6}$$

which was what to be shown.

Similar analysis for $N > 1$ expresses that a certain linear combination $\sum a_k \mathcal{O}_k$ of the operators defined in (5.22) as a linear combination of $\prod \mathcal{P}_i, \mathcal{Q}_1\mathcal{Q}_2, \mathcal{R}_1\mathcal{R}_2$. Therefore it just eliminates one of \mathcal{O}_k from the set of the generators, and it does not introduce non-linear relation among true generators. Direct derivation of similar relations for $E_{6,7,8}$ seems to be much more difficult.

References

- [1] J.M. Maldacena, *The large- N limit of superconformal field theories and supergravity*, *Adv. Theor. Math. Phys.* **2** (1998) 231 [*Int. J. Theor. Phys.* **38** (1999) 1113] [[hep-th/9711200](#)].
- [2] E. Witten, *Baryons and branes in anti de Sitter space*, *JHEP* **07** (1998) 006 [[hep-th/9805112](#)].
- [3] V. Balasubramanian, M. Berkooz, A. Naqvi and M.J. Strassler, *Giant gravitons in conformal field theory*, *JHEP* **04** (2002) 034 [[hep-th/0107119](#)].
- [4] I.R. Klebanov and E. Witten, *Superconformal field theory on threebranes at a Calabi-Yau singularity*, *Nucl. Phys.* **B 536** (1998) 199 [[hep-th/9807080](#)].
- [5] S.S. Gubser and I.R. Klebanov, *Baryons and domain walls in an $N = 1$ superconformal gauge theory*, *Phys. Rev.* **D 58** (1998) 125025 [[hep-th/9808075](#)].
- [6] S. Gukov, M. Rangamani and E. Witten, *Dibaryons, strings and branes in AdS orbifold models*, *JHEP* **12** (1998) 025 [[hep-th/9811048](#)].
- [7] C.E. Beasley and M.R. Plesser, *Toric duality is Seiberg duality*, *JHEP* **12** (2001) 001 [[hep-th/0109053](#)].
- [8] C.P. Herzog and J. McKernan, *Dibaryon spectroscopy*, *JHEP* **08** (2003) 054 [[hep-th/0305048](#)].
- [9] K. Intriligator and B. Wecht, *Baryon charges in 4D superconformal field theories and their AdS duals*, *Commun. Math. Phys.* **245** (2004) 407 [[hep-th/0305046](#)].
- [10] C.P. Herzog and J. Walcher, *Dibaryons from exceptional collections*, *JHEP* **09** (2003) 060 [[hep-th/0306298](#)].
- [11] A. Butti, D. Forcella and A. Zaffaroni, *Counting BPS baryonic operators in CFTs with Sasaki-Einstein duals*, *JHEP* **06** (2007) 069 [[hep-th/0611229](#)].
- [12] D. Forcella, A. Hanany and A. Zaffaroni, *Baryonic generating functions*, [hep-th/0701236](#).
- [13] A. Butti, D. Forcella, A. Hanany, D. Vegh and A. Zaffaroni, *Counting chiral operators in quiver gauge theories*, *JHEP* **11** (2007) 092 [[arXiv:0705.2771](#)].
- [14] J. McKay, *Graphs, singularities and finite groups*, *Proc. Symp. in Pure Math.* **37** (1980) 183.
- [15] M.R. Douglas and G.W. Moore, *D-branes, quivers and ALE instantons*, [hep-th/9603167](#).
- [16] R. Gopakumar and C. Vafa, *Branes and fundamental groups*, *Adv. Theor. Math. Phys.* **2** (1998) 399 [[hep-th/9712048](#)].
- [17] A. Skowroński and J. Weyman, *The algebras of semi-invariants of quivers*, *Transformation Groups* **5** (2000) 361.
- [18] S.S. Gubser, *Einstein manifolds and conformal field theories*, *Phys. Rev.* **D 59** (1999) 025006 [[hep-th/9807164](#)].
- [19] M. Henningson and K. Skenderis, *The holographic Weyl anomaly*, *JHEP* **07** (1998) 023 [[hep-th/9806087](#)].
- [20] S.S. Gubser, I.R. Klebanov and A.M. Polyakov, *Gauge theory correlators from non-critical string theory*, *Phys. Lett.* **B 428** (1998) 105 [[hep-th/9802109](#)].

- [21] E. Witten, *Anti-de Sitter space and holography*, *Adv. Theor. Math. Phys.* **2** (1998) 253 [[hep-th/9802150](#)].
- [22] D. Berenstein, C.P. Herzog and I.R. Klebanov, *Baryon spectra and AdS/CFT correspondence*, *JHEP* **06** (2002) 047 [[hep-th/0202150](#)].
- [23] J.-B. Zuber, *CFT, BCFT, ADE and all that*, [hep-th/0006151](#).
- [24] H.S.M. Coxeter, *Regular polytopes*, 3rd, Dover (1973).
- [25] G. Lusztig, *Affine quivers and canonical bases*, *Publication Mathématiques de l'IHÉS* **76** (1992) 111.
- [26] N. Seiberg, *Electric-magnetic duality in supersymmetric nonabelian gauge theories*, *Nucl. Phys.* **B 435** (1995) 129 [[hep-th/9411149](#)].
- [27] V.G. Kac, *Infinite root systems, representations of graphs and invariant theory*, *Invent. Math.* **56** (1980) 57; *Infinite root systems, representations of graphs and invariant theory — II*, *J. Algebra* **78** (1982) 141.
- [28] M. Domokos and A.N. Zubkov, *Semi-invariants of quivers as determinants*, *Transformation Groups* **6** (2001) 9.
- [29] Y.-H. He, *Some remarks on the finitude of quiver theories*, [hep-th/9911114](#).
- [30] F. Cachazo, S. Katz and C. Vafa, *Geometric transitions and $N = 1$ quiver theories*, [hep-th/0108120](#).
- [31] D. Berenstein and M.R. Douglas, *Seiberg duality for quiver gauge theories*, [hep-th/0207027](#).
- [32] P. Gabriel, *Unzerlegbare Darstellungen I*, *Manusc. Math.* **6** (1972) 71.
- [33] H. Kraft and Ch. Riedtmann, *Geometry of representation of quivers*, in *Representations of Algebra*, P. Webb ed., London Math. Soc. Lect. Note Series **116**, Cambridge University Press, Cambridge U.K. (1986).
- [34] V. Dlab and C.M. Ringel, *Indecomposable representations of graphs and algebras*, *Mem. A.M.S.* **173** (1976).
- [35] V.G. Kac, *Infinite dimensional Lie algebras*, 3rd ed., Cambridge University Press, Cambridge U.K. (1990).
- [36] J.P. Gauntlett, D. Martelli, J. Sparks and D. Waldram, *Sasaki-Einstein metrics on $S^2 \times S^3$* , *Adv. Theor. Math. Phys.* **8** (2004) 711 [[hep-th/0403002](#)].
- [37] S. Benvenuti, S. Franco, A. Hanany, D. Martelli and J. Sparks, *An infinite family of superconformal quiver gauge theories with Sasaki-Einstein duals*, *JHEP* **06** (2005) 064 [[hep-th/0411264](#)].
- [38] I.R. Klebanov and M.J. Strassler, *Supergravity and a confining gauge theory: duality cascades and χ SB-resolution of naked singularities*, *JHEP* **08** (2000) 052 [[hep-th/0007191](#)].
- [39] A. Butti, M. Graña, R. Minasian, M. Petrini and A. Zaffaroni, *The baryonic branch of Klebanov-Strassler solution: a supersymmetric family of SU(3) structure backgrounds*, *JHEP* **03** (2005) 069 [[hep-th/0412187](#)].
- [40] A. Dymarsky, I.R. Klebanov and N. Seiberg, *On the moduli space of the cascading $SU(m+p) \times SU(P)$ gauge theory*, *JHEP* **01** (2006) 155 [[hep-th/0511254](#)].